



AUTOMATIC VACUUM UNIT



Part No. / Art. Nr. / Réf.:
29736



A SAFETY REGULATIONS manual is delivered with this manual.

MEANING OF THE PICTOGRAMS USED IN THIS MANUAL

Pictograms have been inserted into the manual to make it clearer and to indicate particular points that should be observed or taken into account, as follows :



Reading symbol: This pictogram indicates particular points and information given.



Attention symbol: This pictogram indicates that failure to observe this symbol may result in personal injury and possibly damage to the machine. A specific reminder is made of the regulations and/or proper application of certain precautions.



Danger symbol: This pictogram represents the DIN symbol 4844 (hazard warning) that warns of a hazard that could cause death or personal injury with damage to the machine. All personnel working on this machine must comply with this symbol. Work safety regulations must be observed.



Environment protection symbol: This pictogram calls to mind the requirement, during maintenance operations, to sort the waste, store it in a safe place and dispose of it in an environmentally-responsible manner.

SECTION 1. INTRODUCTION

General remark :

If they are used in accordance with their intended purpose, machines bearing EC marking will comply with the requirements of machines directive EC 2006/42/EC



In order to guarantee personal protection and avoid any material damage, it is essential to comply with the instructions given in this manual and all other documents supplied with the machine. The installation and maintenance manual for EVISA type vacuum pumps and additional information on safety instructions are enclosed.



In order to simplify any requests for spare parts or information on your VIDANGEMIL'S, we advise you to write the characteristics indicated on the information plate of your machine on this page, as soon as it is delivered.

1.1. Specification plate fixed to the machine

Type of centrale VIDANGEMILS	
N° de série	

1.2. Use of the system

Intended purpose : the VIDANGEMIL'S is used to collect the oil of motors from automobile vehicles or water by vacuum pumping.



The pumping of fluids other than those referred to below may cause serious bodily injury or be fatal, and cause serious material damage. Consult us for further information

SECTION 2. OPERATION

2.1. Handling, storage

Ensure that the lifting equipment is of sufficient capacity !

If a long period of time (e.g., one year) elapses between the date the machine is delivered and the date it is used for the first time, store the unit in suitable conditions (in a dry place away from dust and vibrations).
Comply with the instructions contained in the vacuum pump installation and maintenance manual.



**Fix the chamber to the floor or on the storage chamber using the holes in the feet.
The bearing capacity of the floor on which it is installed must be sufficient to support its weight.**

2.2. Place of use, temperature

Your VIDANGEMIL'S unit must be operated in a properly ventilated place, free of dust and sheltered from frost.
The maximum room temperature must not exceed 40°C and, if possible, be between + 10°C and + 30°C.

3. OPERATING PRINCIPLE

SECTION 3. OPERATING PRINCIPLE

3.1. Outline diagram

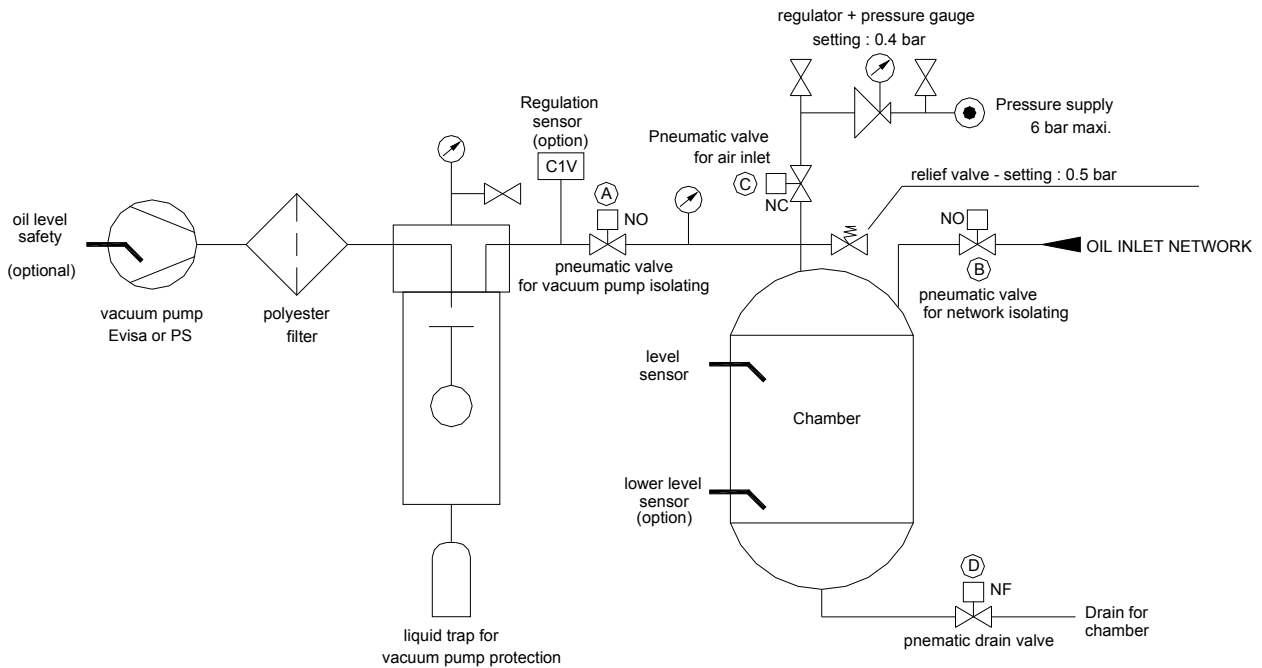

3.2. Operation

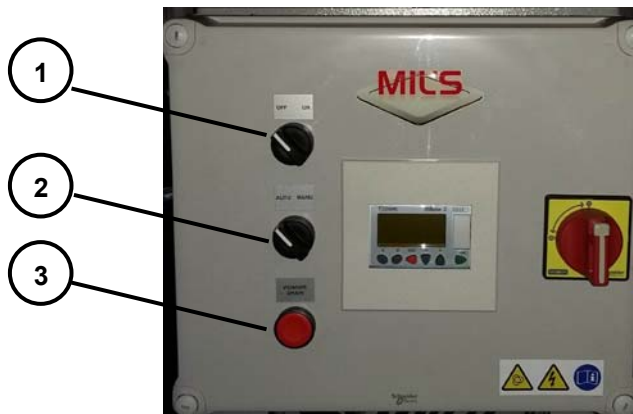

1. ON / OFF button from the vacuum pump
2. "AUTO / MANU" button
3. Button to start a drain

Daily programming:

If the button " Auto/ Manu " is in position "Auto", the power plant works according to a daily schedule from Monday to Friday from 7:00 am till 7:00 pm. Schedules are modifiable. To consult us.

In position " Manu ", the power plant works continuously 24h / 24h and 7j / 7j

3. OPERATING PRINCIPLE

3.2.1. Vacuum pump running

The vacuum pump is automatically running when Time Prog = ON, in low vacuum (if option sensor) and when it's drain phase

The vacuum pump is running or stopping with the ON/OFF switch.

"PUMP RUNS" will appear on the line of the screen.

For disjunction, **DISJUNCT** will appear flashing on the line of the MILLENIUM screen.

Option: if the pump is equipped with oil level sensor and if this starts, after 60 s it will block the pump.

Message "OIL FAULT" appears

3.2.2. Liquid pumping

Status of valves :

- ⇒ **A** (pneumatic valve for isolating pump) : open,
- ⇒ **B** (pneumatic valve for isolating network) : open,
- ⇒ **C** (pneumatic valve for air inlet) : closed.
- ⇒ **D** (pneumatic valve for drain) : closed,

3.2.3. Chamber draining

During this phase the vacuum pump can stay running.

Four events to start draining :

- ⇒ at the time of each powering or from monday to friday at 7 o'clock,
- ⇒ five hours after powering,
- ⇒ with the push-button of drain,
- ⇒ when the liquid level sensor fitted on the chamber is reached.

A message indicates which of these events activated draining.

3.2.3.1. Pumping operation to draining operation

A and B valves are closed in order to isolate the network and the pump.

C valve is open : the pressure in the chamber increases. It is limited with a pressure reducing valve at 0.4 bar.

D valve is open after 60 seconds. The liquid is drained out of the chamber and the draining lasts 5 minutes.

3.2.3.2. Draining operation to pumping operation

C valve is closed : the pressure in the chamber drops. After 30 seconds, A and B valves are open and D valve is closed.

Optional : if a lower liquid level sensor is connected, the message "LOWER SENSOR" appears. A and B valves are closed and the pump is stopped. A draining operation is necessary by the push-button of drain to inactivate the lower sensor.

3.2.4. Liquid trap to protect the vacuum pump

The liquid trap is a safety device. If, by accident, the operator does not respect the maximum chamber level and the level sensor of the chamber (mechanical float) does not work properly, the liquid may flow towards the pump. It will be trapped in the liquid trap before reaching the pump. If a large volume of back-flowing liquid is involved, the level in the liquid trap rises and, on reaching its maximum level, a valve cuts the vacuum.

The liquid trap must then be emptied :

- ⇒ Switch off the vacuum pump,
- ⇒ Open valve ① so that the liquid fills the bottle ② placed under the valve
- ⇒ When the bottle is full, close the valve ①



Unscrew the bottle and empty its contents into a suitable recipient for subsequent recycling according to environmental protection legislation.

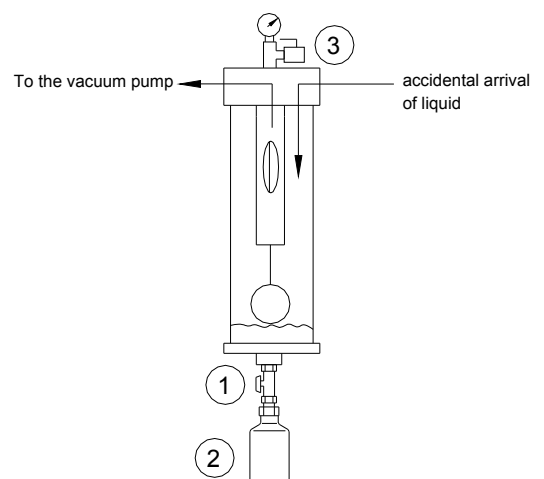

4. INSTALLATION

Once the pot is empty, it is possible that the level sensor (mechanical closure valve) might remain in the closed position. To release it, simply open valve ③ and close it again.

SECTION 4. INSTALLATION

4.1. Network connection

In order to convey liquid correctly and avoid line losses, we recommend 2" pipe (50/60). It must be no higher than 3 metres off the ground. Decline to chamber is necessary to avoid a low point at the end line.

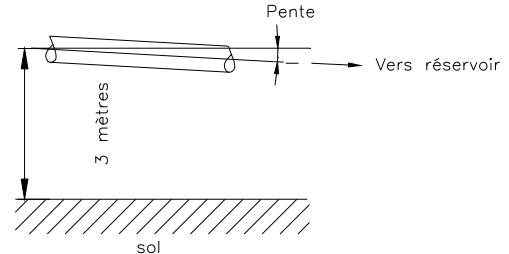

4.2. Drain piping

Connect the drain valve of the chamber to allow the automatic drainage. The pipe must be no higher than 2 meters off the ground.

4.3. Pneumatic connection

Connect the compressed air to the regulator to a maxi. pressure of 6 bar. The air used must be clean and free of moisture. The pressure after the regulator is set to 0.4 bar and the relief valve to 0.5 bar



The regulator and the relief valve are set and sealed in the factory. If the settings of these devices change, high pressure may be created in the chambers which are not designed to operate in these conditions.

4.4. Electrical connection



Power supply must be removed prior to any intervention on the unit. Connection to the power supply must be carried out by a qualified electrician.

Refer to the motors or units rating plates in order to insure that the voltage used on site is that required by the equipment. Connect the unit to power supply using power cord having conductor section capable of supporting the power requirement of the motor.

-For EVISA vacuum pump:

0.75 kW for EVISA E25, 1.1 kW for EVISA E40, 1.5 kW for EVISA E65 → 1.5 mm²

Power supply on L1 – L2 – L3 –Neutral earth (400V).

-For PS12 vacuum pump:

0,58 kW, →1 mm²

Power supply on L + Neutral earth (230V mono)

See the electrical diagram.



Power cables must be protected upstream using a surge protection device in accordance with current legislation and standards of your country.

SECTION 5. START-UP

- ⇒ Check the oil level of the vacuum pump.
- ⇒ Before using the pump, read the pump installation and maintenance manual.
- ⇒ Switching ON the main switch (IG) and push immediately the red Push-Button "STOP" to stop the vacuum pump.
- ⇒ Push the green button "START" to switch on the vacuum pump and check immediately the rotation direction.
- ⇒ Once the vacuum has been created, pumping operations can start.
- ⇒ Four events to start draining :
 - ⇒ at the time of each powering,
 - ⇒ five hours after powering,
 - ⇒ with the button of drain on the cabinet,
 - ⇒ when the liquid level sensor fitted on the chamber is reached.

SECTION 6. MAINTENANCE

In general, inspect daily the condition of all hoses, electrical equipment, chambers, valves, etc.

6.1. Vacuum pump

Daily :

- ⇒ Check the oil level and appearance of oil,
- ⇒ General appearance of the pump.

Every 1000 hours of running or once a year :

- ⇒ Drain the vacuum pump. Oil used is a special oil for vacuum pumps : MV46S.
- ⇒ Replace the oil filter,
- ⇒ Replace the oil separating cartridge.

6.2. Inlet filter

Regularly check the appearance of the filter and change it at least once a year

SECTION 7. PRACTICAL HINTS FOR TROUBLESHOOTING

Fault	Possible causes	Suitable remedies
The pump will not switch on.	<ol style="list-style-type: none"> 1. No power. 2. Fuse tripped. 3. The motor protection relay has tripped. 4. Vanes are broken 	<ol style="list-style-type: none"> 1. Check the network and the power lead. 2. Check the power leads, the control equipment, the pump motor and the fan. 3. Check that the motor thermo-relay has been correctly set. Check the electrical connections. Check that all the electrical connections are firm. 4. Replace vanes.
No suction at the use.	<ol style="list-style-type: none"> 1. The pump is not working. 2. System in drainage phase. 3. The liquid trap is full. 4. System blocked towards the use. 	<ol style="list-style-type: none"> 1. Switch on the pump. 2. Wait the end of the drainage phase. 3. Empty it. 4. Check.
Drainage pressure greater than 0.5 bar.	<ol style="list-style-type: none"> 1. Setting of pressure reducing and relief valve has changed. 	<ol style="list-style-type: none"> 1. Consult us.

SECTION 8. MILLENIUM

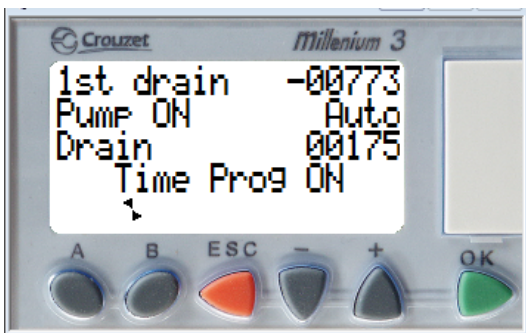

- ⇒ 1st line : displays the status of the unit,
- ⇒ 2nd line : , displays the vacuum and the vacuum pump running and "Auto/Manu" mode
- ⇒ 3rd line : displays time + day and phases of draining
- ⇒ 4^{ème} line : displays parameters and alarms.

8. MILLENNIUM

8.1. Status of the unit (1st line)

The first line displays following information :

- 1st DRAIN :** 1 second after the start up, evacuation of liquid starts, or each morning at 7 o'clock from monday to friday.
- SENSOR DRAIN :** the liquid level sensor fitted on the chamber is reached, so the evacuation starts.
- PB DRAIN :** The evacuation starts by pushing the red push-button.
- PROG DRAIN :** The evacuation of liquid starts automatically 5 hours after the start up or 5 hours after the evacuation of liquid of the morning.
- PUMPING :** The unit is in phase of liquid pumping.

8.2. Draining phases (3rd line)

When the evacuation of liquid starts, the second line displays following information :



- VAC.BREAK 0060 :** Period of setting to atmospheric pressure and pressure rising.
'60' are corresponding to 60 seconds and they are deducted.
- DRAIN 0300 :** Period of liquid evacuation.
'300' are corresponding to 300 seconds and they are deducted.
- EVAC.PRESS. 0030 :** Period of pressure outlet at the end of the liquid evacuation.
'30' are corresponding to 30 seconds and they are deducted.

8.3. Parameters (4eme line)

To see the parameters, press the  button :

- STOP 00900 :** Pumps'stop threshold at -900 mbar. This threshold is modifiable.
- HYST 00100 :** Hysteresis of activation of the pumps' startup at - (900-100) = -800 mbar.
This threshold is modifiable.
- FLEXO TIME 00600:** Delay time of pump stopping, on seconds, that is 600s (10min). This value is modifiable.
- VAC.BREAK.T 0060 :** Time of the phase of break-in empty on seconds, is 60 s This value is modifiable.
- DRAIN.TIME 0300 :** Time of the phase of evacuation of liquid on seconds, that is 300 s (5min)
This value is modifiable
- EVAC.PRESS.T 00300 :** Time of pressure evacuation in on seconds, here 30 s.
This value is modifiable.
- PUMP HM 00000 :** Number of hours of step of the pump
- TOTAL HM 00000 :** Number of hours total under stress of the central
- M 3033:** program number
Or M3043

Modification of parameters :

By pressing the  button, display the parameter for setting. Increase and decrease the value by the  or  button.

To valid press the  button.

If the  button is inactive during 2 minutes, then the line 4 is automatically back in white

8.4. **Pump start (2nd line)**

If the vacuum pump tripped, "***DISJUNCT***" appears on the 2nd line.

If the button Start/Stop is on Stop, the message "Start/Stop button ?" appears on the 2nd line.

If the button " Auto / Manu " is on "Auto", then the message "Auto" appears on the line 2.
On the contrary, the message " Manu " appears to the screen

Nota: To acknowledge the "DISJONCT" alarm, presse the key 

9. DIMENSIONS

29736

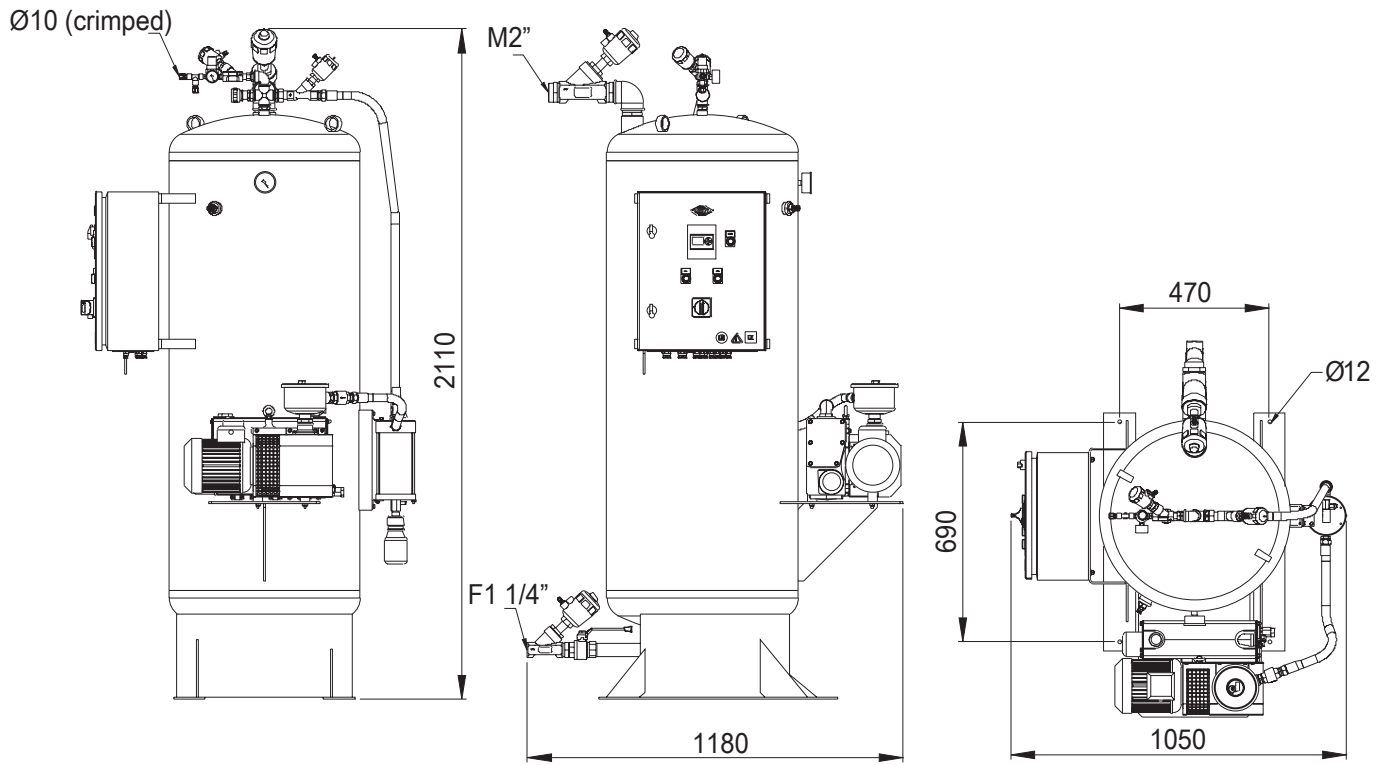

10. CONNECTING WASTE OIL SENSOR

When the unit is connected to an external waste oil tank, a level sensor such as 23132/23154 can be installed to pause the vacuum unit once the external tank is full.

Providing that the waste oil sensor has been installed in the tank, connect it to the unit connection box to terminals **1** and **7**. The signal is NC, meaning that when the tank is not empty, the circuit will be closed.

The unit will blink "2 chamber" when the tank is full, or if the level sensor is defective.

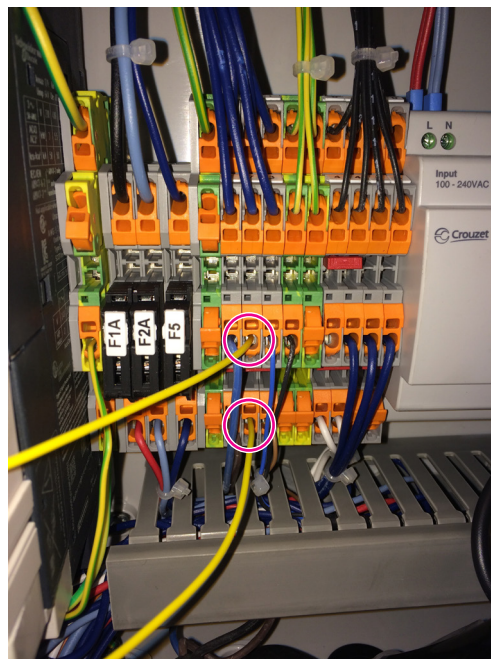

Spare parts

Part no	Description	Used in
2090200	Electric motor 0,75 kW	29736
2495510	Service kit 3000 h	29736
2495521	Oil for vacuum pump (included in service kit)	29736

EN

Alentec&Orion AB, Grustagsvägen 4, SE-13840, Älta, Sweden, declares by the present certificate that the mentioned machinery is in conformity with the following standards or other normative documents (TÜV S9211282), (DIN 24558 / 10.91), (DIN EN 292 / 2/11.91) and has been declared in conformity with the EC Directive **(2006/42/CE, 73/23/CE and 89/336/CE)**.



Krister Tynhage
Managing Director



Olle Berglund
Product Manager