



PARTS & TECHNICAL SERVICE GUIDE



NEX-U· INSTALLATION MANUAL



(Version 4.1 ENG)

DOCUMENT: NEX·U· INSTALLATION MANUAL.
 Revision: 4.1 ENG
 Date: July 2024

Versions

<u>Revision</u>	<u>Changes</u>
0	Draft Edition (03.09.2018)
1	Minor changes (20.09.2018)
2	U·Tank parameterization (05.02.2019)
2.0 ENG	Updating to NEX·U· Version 2.0 Wi-Fi® configuration (16.04.2019) Minor Changes (16.04.2019) Calibration Process (16.04.2019)
2.1 ENG	New U·Connect (16.11.2022) Android App updating (16.11.2022) Minor changes (16.11.2022)
3.0 ENG	Not edited
4.0 ENG	Windows® 11 U·NET Configuration Settings Updating to NEX·U· Version 4.0 (01.10.2023)
4.0.1 ENG	NEXU branding (XX.01.2024)
4.1 ENG	U·Link and U·Net updating (23.07.2024)

INDEX**1 HOW TO USE THIS MANUAL****2 COMPONENTS PRESENTATION**

- 2.1 KEYPADS (U·DAT, U·DAT POWER+)^o
- 2.2 ADDITIONAL POWER SUPPLY (U·POWER, U·POWER+)
- 2.3 FLOW CONTROL UNIT (U·VALVE)
- 2.4 FLOW DISPENSE MANAGEMENT (U·COUNT)
- 2.5 REMOTE DISPLAY UNIT (U·VIEW)
- 2.6 INTELLIGENT COMPACT PULSE METER (U·METER, U·METER+)
- 2.7 HAND HELD DISPLAY (U·VISION, U·VISION+)
- 2.8 LINE PULSE METER (U·PULSER, U·PULSER+)
- 2.9 DISPENSING VALVE (U·LINK)
- 2.10 TANK LEVEL MONITOR MODULE (U·TANK)
- 2.11 CENTRAL PROCESSING UNIT (U·NET)
- 2.12 NETWORK EXTENDER
- 2.13 CODED KEYS SET (CK5)
- 2.14 FLOW CONTROL UNIT
- 2.15 VOLUMETRIC PROBE (VP-4M)
- 2.16 ADJUSTABLE LEVEL CONTACT PROBE
- 2.17 FLASH LIGHT INDICATOR (ATS-FLASH)
- 2.18 BAR CODE READER (LCB)
- 2.19 U·CONNECT

3 INSTALLATION AND CABLING

- 3.1 NETWORK TOPOLOGY
 - 3.1.1 WIRED INSTALLATION
 - 3.1.2 WIRELESS INSTALLATION
 - 3.1.3 HYBRID INSTALLATION
- 3.2 LOCATION OF THE CONNECTION POINTS / INDICATING LEDS
 - 3.2.1 U·DAT / U·DAT Power+
 - 3.2.2 U·POWER / U·POWER+
 - 3.2.3 U·VALVE / U·VALVE+
 - 3.2.4 U·COUNT
 - 3.2.5 U·VIEW
 - 3.2.6 U·METER / U·METER+
 - 3.2.7 U·VISION / U·VISION+
 - 3.2.8 U·PULSER / U·PULSER+
 - 3.2.9 U·TANK
 - 3.2.9.1 STAND BY DISPLAY
 - 3.2.10 U·NET
 - 3.2.11 U·CONNECT
- 3.3 FIXING OF THE ELEMENTS
 - 3.3.1 U·DAT / U·DAT+
 - 3.3.2 U·POWER / U·POWER+
 - 3.3.3 U·VALVE / U·PULSER / U·PULSER+
 - 3.3.4 U·COUNT / U·VIEW
 - 3.3.5 U·METER / U·METER+
 - 3.3.6 U·VISION / U·VISION+
 - 3.3.7 U·TANK
 - 3.3.8 U·CONNECT
 - 3.3.9 U·LINK
- 3.4 NETWORK CABLING
 - 3.4.1 CABLING FROM U·DAT / U·DAT POWER+ TO U·VALVE
 - 3.4.2 CABLING U·VALVE / U·METER / U·METER+ TO U·VALVE / U·METER / U·METER+
 - 3.4.3 CABLING FROM U·DAT / U·DAT POWER+ TO U·DAT / U·DAT POWER+

- 3.4.4 CABLING FROM U·DAT / U·DAT+ TO U·VALVE (U·METER / U·METER+) TO U·DAT / U·DAT+ (ONLY FOR TWO CONNECTORS U·DATS)
- 3.4.5 CABLING FROM U·NET TO U·DAT / U·DAT+
- 3.4.6 CABLING FROM U·TANK TO U·DAT / U·DAT+
- 3.4.7 CABLING FROM U·VALVE / U·METER / U·METER+ TO U·CONNECT
- 3.4.8 POWER SUPPLY CONNECTION

4 SETTING PROCEDURE AND DEFINITION OF THE PARAMETERS

- 4.1 SETTING PROCEDURE
- 4.2 ADDRESS DEFINITION
- 4.3 END OF LINE (EOL) RESISTORS (FOR TWO-CONNECTOR U·DATS)
- 4.4 END OF LINE (EOL) RESISTORS (FOR THREE-CONNECTOR U·DATS)
- 4.5 LOCAL PARAMETERS SETUP
 - 4.5.1 LOCAL PARAMETERS SETUP ON A U·VALVE / U·VALVE +
 - 4.5.2 LOCAL PARAMETERS SETUP ON A U·METER / U·METER+
 - 4.5.3 LOCAL PARAMETERS SETUP ON A U·LINK
 - 4.5.4 LOCAL PARAMETERS SETUP ON U·DAT / U·DAT+
 - 4.5.5 LOCAL PARAMETERS SETUP ON U·COUNT
 - 4.5.6 LOCAL PARAMETERS SETUP ON U·VIEW
 - 4.5.7 LOCAL PARAMETERS SETUP ON U·VISION
 - 4.5.8 LOCAL PARAMETERS SETUP ON U·VISION+
 - 4.5.9 LOCAL PARAMETERS SETUP ON U·TANK
 - 4.5.10 LOCAL PARAMETERS SETUP ON U·NET
 - 4.5.11 LOCAL PARAMETERS SETUP ON U·CONNECT
 - 4.5.12 LOCAL PARAMETERS SETUP ON U·POWER / U·POWER+
 - 4.5.13 LOCAL PARAMETERS SETUP ON A NETWORK EXTENDER
- 4.6 DIAGNOSIS OF THE NETWORK STATUS

5 NEX·U· REQUIREMENTS

6 SOFTWARE CONFIGURATION

- 6.1 INSTALLATION PROCESS
 - 6.1.1 HOW TO CHANGE THE IPv4 ADDRESS FOR A LOCAL NETWORK
 - 6.1.1.1 WINDOWS 10
 - 6.1.1.2 WINDOWS 11
- 6.2 CONFIGURATION PROCESS
 - 6.2.1 PRODUCTS
 - 6.2.2 DEVICES
 - 6.2.2.1 U·TANK
 - 6.2.2.2 TANK
 - 6.2.2.3 U·DAT
 - 6.2.2.4 U·VALVE / U·VALVE+
 - 6.2.2.5 U·METER / U·METER+
 - 6.2.2.6 U·COUNT
 - 6.2.2.7 U·LINK
 - 6.2.2.8 U·VIEW
 - 6.2.2.9 U·VISION
 - 6.2.2.10 U·VISION+
 - 6.2.2.11 AIR SV
 - 6.2.3 GROUPS
 - 6.2.4 DISPENSE SCRIPT
 - 6.2.5 ERP / DMS
 - 6.2.6 SEND
 - 6.2.7 SYSTEM TOOLS
 - 6.2.8 NETWORK

7 MANAGER

- 7.1 HOME
- 7.2 TRANSACTIONS

- 7.3 TANKS
- 7.4 USERS
- 7.5 EVENTS
- 7.6 DEVICES
 - 7.6.1 DISPENSE POINT
 - 7.6.2 U·DAT
 - 7.6.3 U·TANK
 - 7.6.4 U·VISION+
 - 7.6.5 AIR SV
- 7.7 CONFIGURATION
 - 7.7.1 PRODUCTS
 - 7.7.2 GROUPS
 - 7.7.3 DISPENSE SCRIPT
 - 7.7.4 SYSTEM TOOLS
- 8 QUICK PANEL**
- 9 VIRTUAL KEYPAD**
- 10 U·LINK MENUS**
- 11 U·DAT OPERATION**
 - 11.1 DISPENSE MENU
 - 11.2 STOCKS MENU
 - 11.3 COMPLETED TRANSACTIONS MENU
 - 11.4 CONFIGURATION MENU
- 12 U·VISION+ OPERATION**
- 13 U·LINK MODES**
- 14 HOSE REEL CALIBRATION**
- 15 U·LINK CALIBRATION**
- 16 U·TANK ANALOGUE PROBES CALIBRATION**

1 HOW TO USE THIS MANUAL

This manual is divided into sixteen chapters. Please read all of them before making the installation and configuration of the NEX·U·.

Chapter two describes all the elements of the system.

Chapter three describes how fix and wire all the elements

Chapter four describes the setting procedure and the local parameters definition.

Chapter five describes the requirements for connecting the NEX·U· to the customer network.

Chapter six defines how to make the configuration of the installation in the U·Track.

Chapters seven and eight describe the menus for the person or persons who will oversee controlling the U·Track (NEX·U· software)

Chapters nine to ten describes the menu for the user (person or persons who will supply fluid)

Chapters eleven to thirteen describe operation modes

Chapters fourteen and fifteen describe how to calibrate hose reels

Chapter sixteen describes how to calibrate analogue probes

NOTE: Chapters seven to sixteen are NOT part of the configuration process

2 COMPONENTS PRESENTATION

NEX·U· is made up of the following components:

2.1 KEYPADS (U·Dat, U·Dat Power+)

This unit is one of the interfaces User/System through the keypad and the display.

There are two versions for this unit:

- U·Dat Power+ which can open up to 8 solenoid valves (Max. output power 320 W)
- U·Dat which can open up to 2 solenoid valves (Max. output power 75 W)

The power supply is to be 115 VAC or 230 VAC – 50 Hz.



2.2 ADDITIONAL POWER SUPPLY (U·Power, U·Power+)

U·Power / U·Power+ connects using CANBUS cable to a U·Valve, U·Valve+, U·Meter, U·Meter+, U·Count or U·View whenever the power supplied by a U·Dat / U·Dat Power+ keypad is not present.

There are two versions for this unit:

- U·Power+ which can open up to 8 solenoid valves (Max. output power 320 W)
- U·Power which can open up to 2 solenoid valves (Max. output power 75 W)

The power supply is to be 115 VAC or 230 VAC – 50 Hz.



2.3 FLOW CONTROL UNIT (U·Valve)

This flow control unit is composed by:

- A solenoid valve
 - A pulser (328 pulses per litre)
 - A filter
 - An electronic board that controls part of the dispense procedure.
- It includes an integrated display that can show the hose reel



- number (in stand-by state) and the delivered quantity (when dispensing)
- A Bluetooth module that connects the device to a U·Vision

It can be linked to the system via CANBUS or Wi-Fi®. The connection threads are F1/2" (inlet and outlet). Compatible with oil and cooling.

2.4 FLOW DISPENSE MANAGEMENT (U·Count)

It is used for controlling an external flow control unit (24VDC solenoid valve and pulser). It can be considered as the electronic part of an U·Valve and, therefore, it has got a display that works in the same way as in the U·Valve, U·Valve+.



It can be linked to the system via CANBUS.

It has a Bluetooth module that connects the device to a U·Vision / U·Vision+.

2.5 REMOTE DISPLAY UNIT (U·View)

It shows the dispensed quantity when a transaction through certain U·Valve, U·Valve+, / U·Count is taking place.



It is used to have an additional indication (apart from the one in the U·Valve, U·Valve+, U·Count, U·Meter, U·Meter+ display)

A U·View can show the quantity dispensed by several units (not simultaneously)

2.6 INTELLIGENT COMPACT PULSE METER (U·Meter, U·Meter+)

This compact pulse meter unit is composed by:

- A pulser.
 - An electronic board that controls part of the dispense procedure.
- It includes an integrated display that can show the hose reel number (in stand-by state) and the delivered quantity (when dispensing)



- Additionally, a Bluetooth module can be installed to the device to be linked to a U-Vision. Then U-Meter becomes a U-Meter+

Compatible with different fluids depending on the model.

2.7 HAND HELD DISPLAY (U-Vision, U-Vision+)

This module is a Hand-held display module to fit a NEX-U oil control handle.

Includes a backlight display connected via Bluetooth® with a U-Valve, U-Valve+, U-Meter+ or U-Count module.

The U-Vision has a screen that repeats the measurement that is shown in the previous devices

The U-Vision+ can do the same as the U-Vision and it has an access keypad that allows introducing work orders.



2.8 LINE PULSE METER (U-Pulser, U-Pulser+)

The U-Pulser+ is a high accuracy line pulse meter module combined with a 24 VDC solenoid valve and an inlet filter screen. Reduces installation time and eliminates the risk of leaks when using separate components. Compatible with oil and coolant

Equipped with fast connection in/out CANBUS terminals. It can only be connected to a U-Count module. This meter does not have a display or function buttons.

The U-Pulser is a high accuracy line pulse meter. It is equipped with connection terminal and valve open indication light. It can only be connected to a U-Count module. This meter does not have a display or function buttons and requires a 24 VDC solenoid valve. Compatible with oil and coolant



2.9 DISPENSING VALVE (U·Link)

Dispensing gun for measuring and controlling dispensed fluid. For lubricants and coolant solutions.

This flow control unit is composed by:

- A solenoid valve.
- A pulse generator
- An electronic board
- A control gun (filter included)

Power supply is made by 4 x 1.5 VDC AA batteries

It can be set in liters, gallons, quarts, and pints

The gun automatically switches off after 30 seconds of inactivity to save energy. If you press any of the UP/DOWN keys, the display is activated.



2.10 TANK LEVEL MONITOR MODULE (U·Tank)

This module is capable of controlling two tanks. When mounted in a NEX·U·system it keeps real time inventory and increases operation safety preventing air entering pumps when the tank is empty and overflow during clean oil delivery and in waste oil storage tanks. It can also be used to control the general air supply to the pumps and the air supply for each pump.

The U·Tank has two independent graphic displays and level bars, each of them shows the inventory available in each tank. It also has a set-up keypad for inventory adjustment if required.



2.11 CENTRAL PROCESSING UNIT (U·Net)

The U·Net is the key NEX·U·component. It is the central processing unit that controls the system communications and houses the U·Track software. This has to be connected to the customer computer network.



The U·Net includes a 2.4 GHz processor and 4 GB RAM. It controls the system functions and it manages the wired and wireless communication between the NEX·U· components.

It has two CANBUS ports (IN/OUT) for wired communications, a ZigBee® board and an ethernet port that allows U·Net to connect to an existing Wi-Fi® network or to create a dedicated Wi-Fi® network.

Power supply is 5 VDC through a 250VAC / 5 VDC power supply (included).

Link between U·Link / Network Extender and U·Net is made by ZigBee® communication.

Link between U·Lubetrack (NEX·U· app) and U·NET is made by Wi-Fi® communication.
WARNING: This option is not available on August 2024.

2.12 NETWORK EXTENDER

ZigBee® repeater. It must be installed if communication strength between U·Net and U·Link is too low.

No need to make any configuration. It links to the NEX·U· ZigBee® network automatically. Power supply is 250 VAC



2.13 CODED KEYS SET (CK5)

Coded key with a secret ID for quick identification on the coded key reader on U·Dat and U·Dat power+.



2.14 FLOW CONTROL UNIT

This flow control unit is composed by:

- A solenoid valve
- A pulser
- A filter

The connection to the piping is F1/2" (inlet and outlet).

Compatible with different fluids depending on the model.

It has to be controlled by a U·Count.



2.15 VOLUMETRIC PROBE (VP-4M)

Piezoelectric probe for controlling real stock on a tank.

Maximum height: 4 meters

Pressure setting: 400 mBar

It has to be controlled by a U·Tank.

Please check liquid compatibility before using.



2.16 ADJUSTABLE LEVEL CONTACT PROBE

Adjustable length contact probe
 Length: 5.0 meter
 Tank connection: M2”G
 It has to be controlled by a U-Tank.



2.17 FLASH LIGHT INDICATOR (ATS-FLASH)

Light and sound indicator for high or low tanks stock level.
 It has to be controlled by a U-Tank



2.18 BAR CODE READER (LCB)

Bar code reader to be connected to a U-Dat. For use with bar code work orders or bar coded ID users.
 RS232 hosts interface
 1D and 2D barcodes.
 Barcode scanning on PC, tablet and mobile screens



2.19 U-CONNECT

This device is to be integrated in the system to allow Wi-Fi® connection between components.



3 INSTALLATION AND CABLING

3.1 NETWORK TOPOLOGY

NEX·U· allows three different configurations:

- **Wired:** In the standard case we have only one line common to all the units of the system. In this line you must connect all the elements of the system following the CANBUS philosophy.
- **Wireless:** In the standard case, communication is made via Wi-Fi®. The only wiring you must connect is for power supply.
- **Hybrid:** A mix of the two previous ones.

As a rule, one power supply can supply a maximum of 8 units for U-Dat power+ or U-Power+ and a maximum of 2 units for U-Dat or U-Power.

3.1.1 WIRED INSTALLATION

An example of how to lay a wired installation can be seen in this figure.

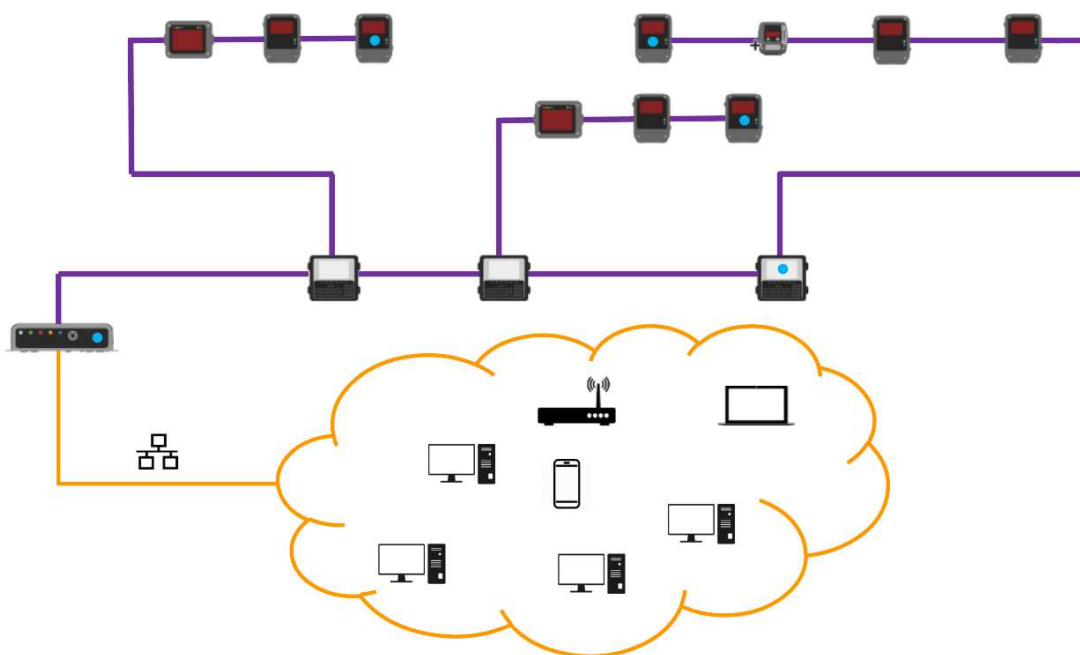

In this case, you see only magenta wiring. This wiring carries power and communication. Yellow wiring represents the customer computer network.

For NEX·U· cabling red and black wires are used for power and white, blue and screen are used for data.

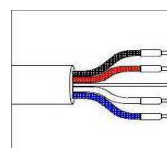

NOTE: Although wiring colors could be used in another way, it is highly recommended to follow this rule.

3.1.2 WIRELESS INSTALLATION

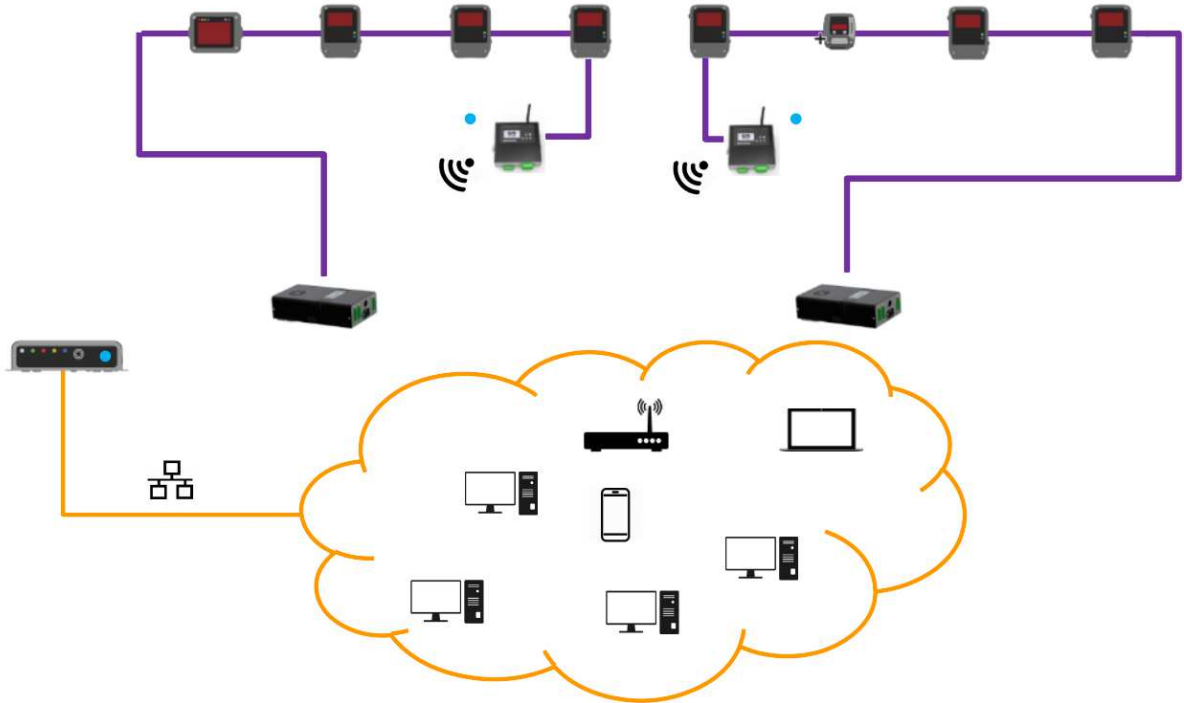

In this case the U·Net is connected to a Wi-Fi® Router and it connects (and transfers information) to two U:Connect that are wired to the GROUP connector of the U.Power+.

3.1.3 HYBRID INSTALLATION

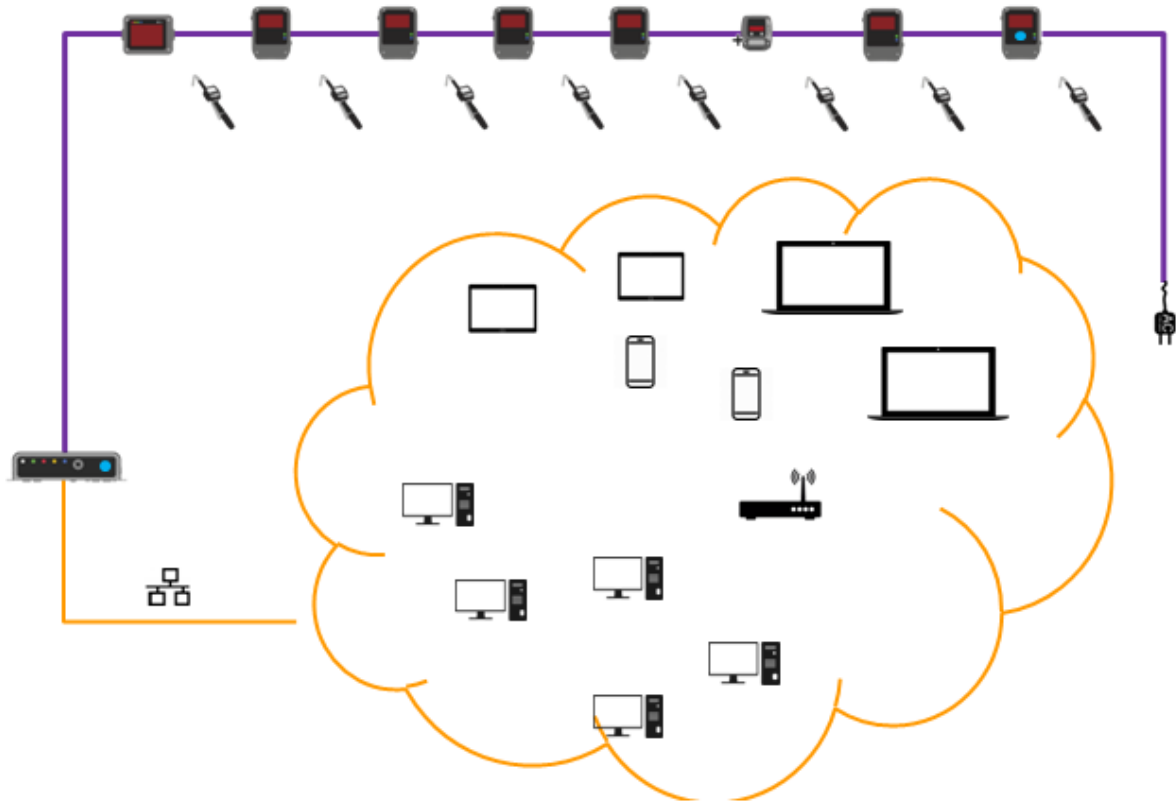

In this case, you can see a mix between wired installation and wireless installation (between the U-Valve+ and the Wi-Fi® Router).

In all the cases, Wi-Fi® and wired communication is made by NEX·U·installer but, as NEX·U· is connected to the customer computer network, U·Track can be accessed via any PC/Tablet/Mobile which is in the network (either wired or Wi-Fi®)

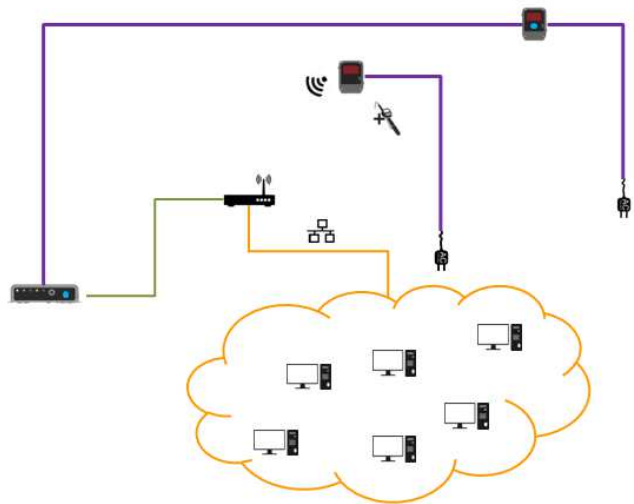

3.2 LOCATION OF THE CONNECTION POINTS / INDICATING LEDS

3.2.1 U-DAT / U-DAT Power+

We can find this front board:



You will find QWERTY and numerical boards and an RFID reader (8)

In the lower part we will find this board:

1. By-pass key switch: It bypasses the units which are powered up by the U-Dat.
2. BUS OUT Quick Connector: It transfers power and communication to the network. Wiring from this BUS OUT connector has to be linked to BUS IN connector if connected to another U-Dat / U-Dat Power+
3. BUS IN Quick Connector: It transfers communication (not power) to the network. Wiring from this BUS IN connector has to be linked to BUS OUT connector if connected to another U-Dat / U-Dat Power+

IMPORTANT: In the last two cases (2 and 3), if the items to be connected need to be powered up, then all the wires (BLACK/RED/SCREEN/WHITE/BLUE) must be connected and it must be done only in the BUS OUT connector. If they only need to be connected for communications then only SCREEN/WHITE/BLUE have to be connected (no matter if it is made in BUS IN or BUS OUT connector)

4. RS232 Port: Allows peripheral devices connections. Mainly for service.
5. USB Port: Allows peripheral devices connections. Mainly for service and updating.
6. iButton[®] Reader: Allows identification via iButton[®] key
7. Power Connector: IEC Power Socket for 240 VAC or 110 VAC, 50 / 60 Hz. Wiring for this, connector must be 3 x 1.5 mm² minimum.

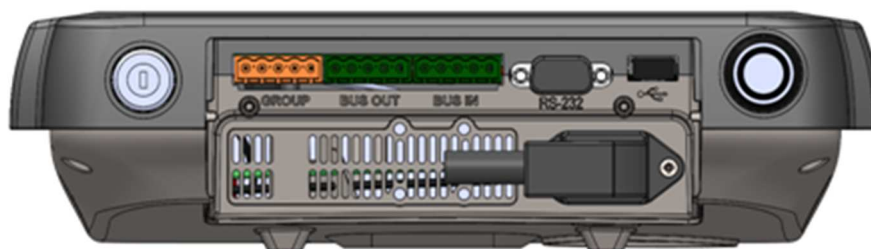

You will see there is another connector (orange colour) marked as GROUP and the philosophy is a little bit different and it implies different wiring

Now BUS IN and BUS OUT are only used for transferring communication and GROUP is used for transferring power and communication to the elements which are connected to that connector. As a guidance, the wire that is connected to GROUP is the one that is marked with a red arrow.

Wiring for U·Dat and U·Dat Power+ is as follow.

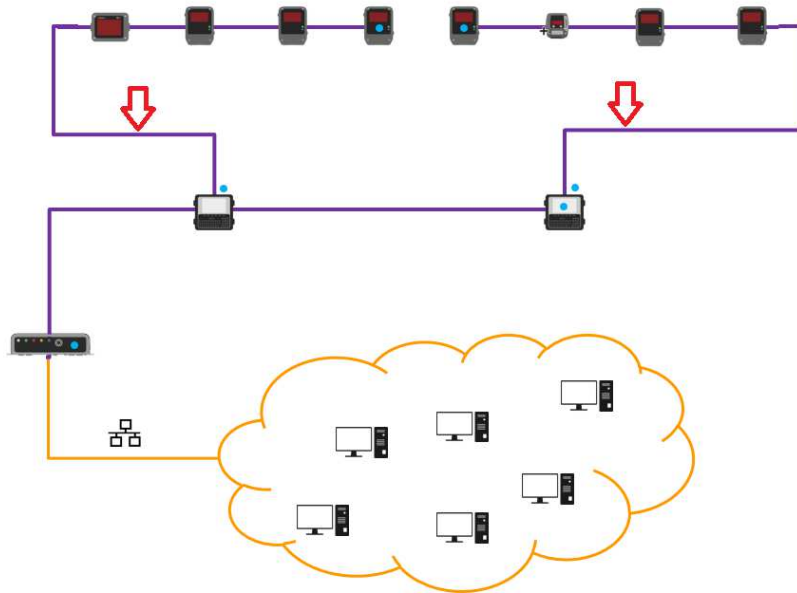

For U·Dat and U·Dat Power +, we can find this board:

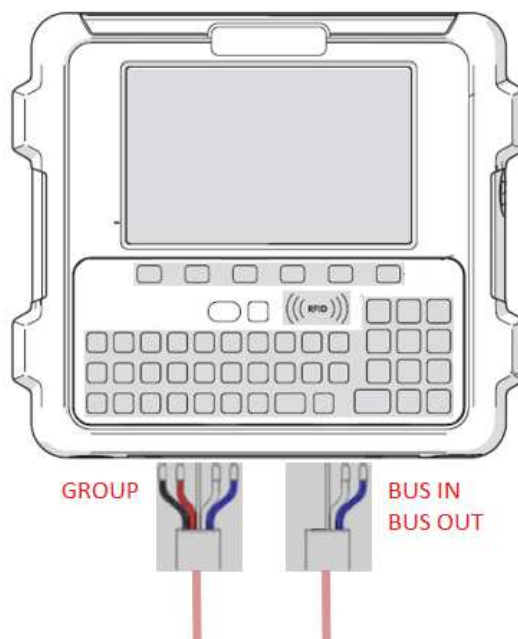

Be aware that this is the standard way of connecting. Please check chapter 3.4 for wiring.

3.2.2 U-POWER / U-POWER+

There are three terminals the ones that have to be used are the ones at both sides are BUS IN and BUS OUT.

The one in the middle is GROUP

Wiring connection will be the same as per U-Dat / U-Dat Power+ .



3.2.3 U-VALVE / U-VALVE+

There are two terminals (IN and OUT)

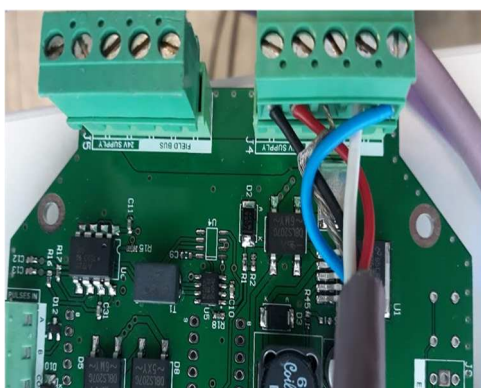

Regarding LEDS and buttons you can find



Address indication / Delivered quantity

S.V. ON

Solenoid opening indication

BYPASS

Bypass indication

ONLINE

Online CANBUS indication

E.O.L.

End of Line indication

F1

Configuration buttons

F2

3.2.4 U-COUNT

As per the U-Valve, there are two terminals (IN and OUT) for the CANBUS

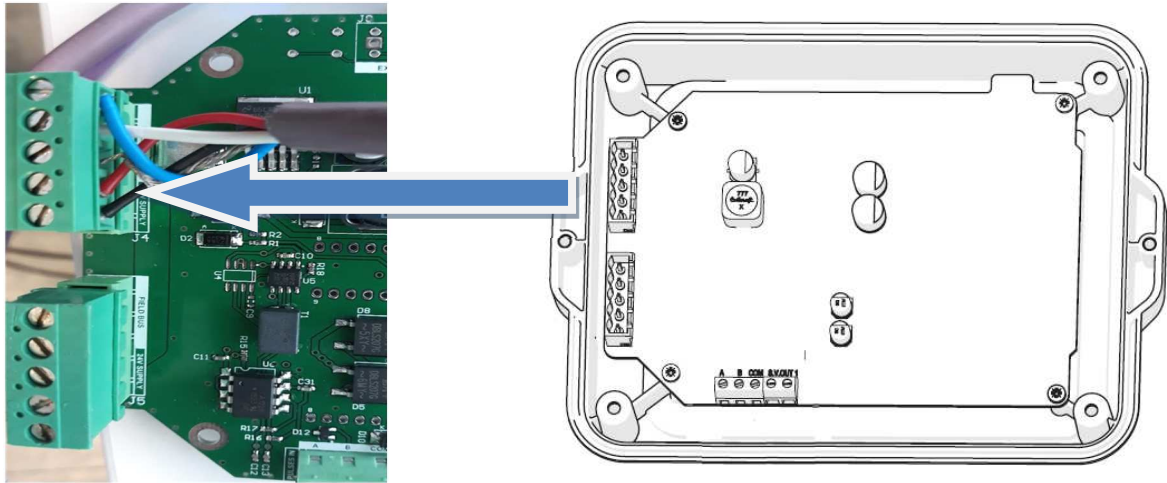

For connecting the U-Count with external flow control unit (24VDC solenoid valve and pulser), you need to use the A B COM SV OUT1 terminals

Connect the COM terminal of the pulse meter to the COM terminal (5) of the U-Count electronic board. Connect the pulse generator terminal of the pulser to terminal “A” (9) of the U-Count. If the pulser has a double reed switch connect the other pulse generator terminal of the pulser to terminal “B” (7) of U-Count electronic board.

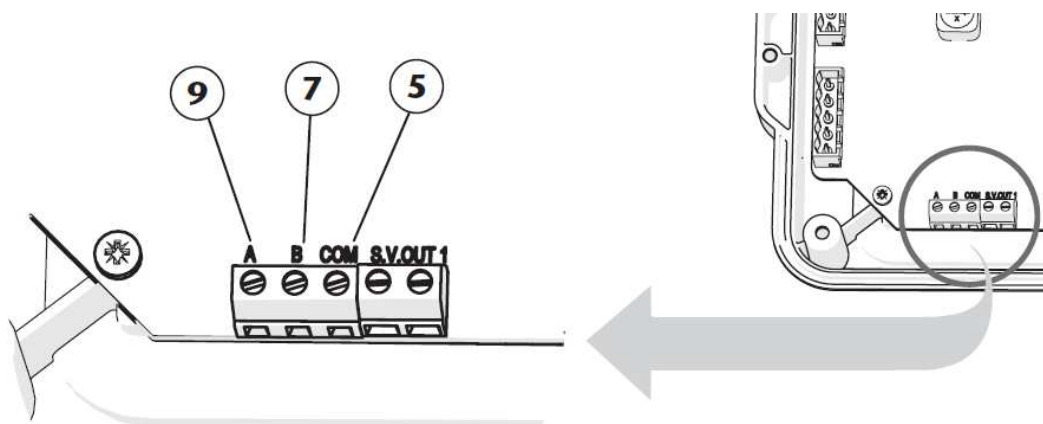

The device has 3 screen display modes, named “standby mode, “standard” mode and “XXL” mode.

The “standby” mode (figure 1) is the display mode shown when no transaction is in progress. While a transaction is being made, the screen will show the “standard” mode (figure 2) or the “XXL” (figure 3) according to the device configuration (see the “menu configuration” section for more details).

Depending on the screen mode, the unit address (1), the fluid volume dispensed (2), the progress status bar of the transaction (3) or the indicator which shows that the solenoid valve is open (4), will be displayed.

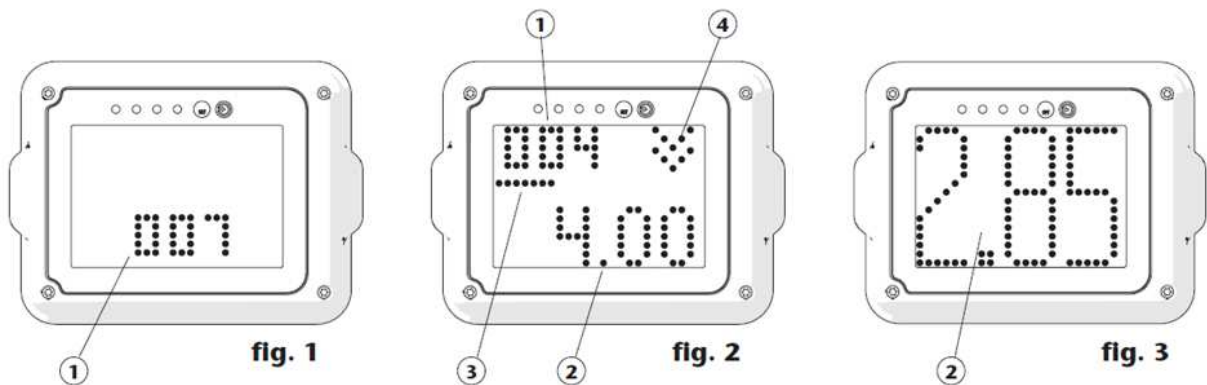

Regarding LEDS and buttons you can find

- 1 - Address indication / Delivered quantity
- 2 and 3 - Configuration buttons
- 4 - Indication LEDS. From left to right Solenoid opening indication, bypass indication, online CANBUS indication, End of Line indication.

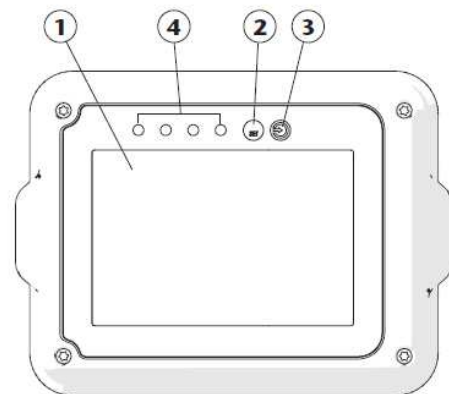

3.2.5 U-VIEW

As per the U-Valve, there are two terminals (IN and OUT) for the CANBUS

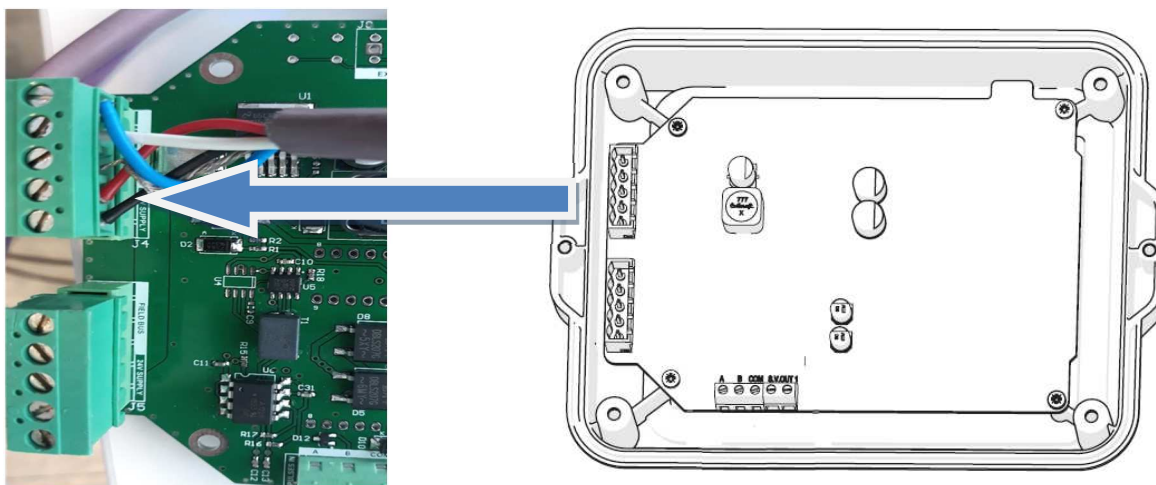

The device has 3 screen display modes, named “standby mode, “standard” mode and “XXL” mode.

The “standby” mode (figure 1) is the display mode shown when no transaction is in progress. While a transaction is being made, the screen will show the “standard” mode (figure 2) or the “XXL” (figure 3) according to the device configuration (see the “menu configuration” section for more details).

Depending on the screen mode, the unit address (1), the fluid volume dispensed (2), the progress status bar of the transaction (3) or the indicator which shows that the solenoid valve is open (4), will be displayed.

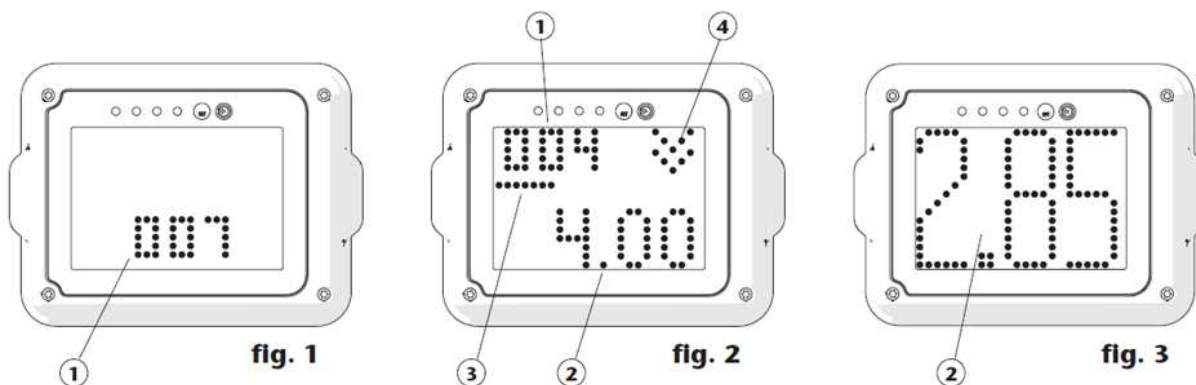

Regarding LEDS and buttons you can find

- 1 - Address indication / Delivered quantity
- 2 and 3 - Configuration buttons
- 4 - Indication LEDS. From left to right: Online CANBUS indication, End of Line (EOL) indication.

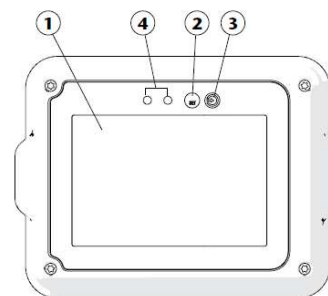

3.2.6 U·METER / U·METER+

Plug in the 2 pole male connector (6) in the 2 pole female connector (7) of the unit.

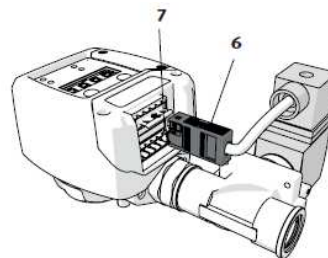

Connect each wire of the CANBUS cable to the 5 pole male plug according to the scheme.

NOTE: Depending on installation layout, it may be possible that in one of the 5 pole plugs, the power wires (red/black) must be left unconnected.

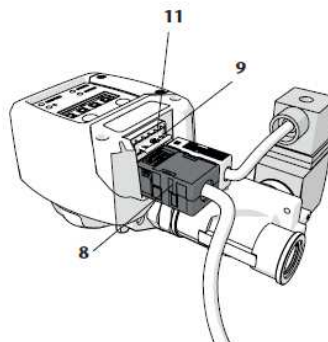

Plug in the 5 pole connector (8) in either of the 5 pole female connectors of the unit. In case that only one male connector is connected, use the bottom female socket. Plug into the upper female socket of the unit the protection cap (11).

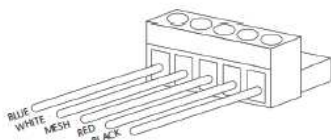

In order to install the Bluetooth kit (if not already installed from factory), follow the next steps:

- Turn off and disconnect the power source of the unit.
- Remove the plastic cover (1) unscrewing the screws (2).
- Insert the wireless PCB kit (3) in the socket as it is shown. Pay attention to PCB orientation.
- Mount the new provided cover (4) with the two screws (2).
- Turn on and/or connect again the unit power source.
- At this point, the unit is already prepared to be paired with a U·Vision or U·Vision+ unit.

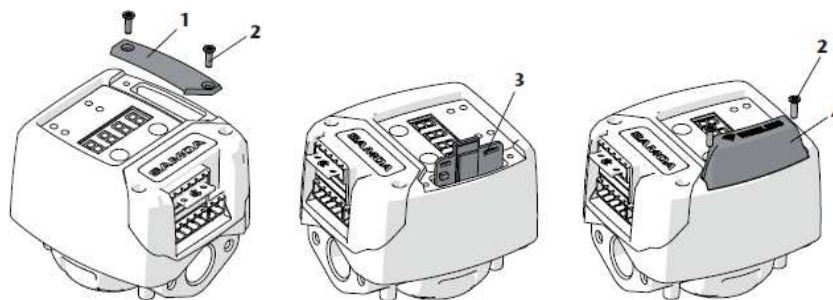

Regarding buttons F1 and F2, apart from being used for configuration, they give more information.

Press and hold F1 button to show the installed firmware version in the display.

Press and hold F2 button to show the power supply voltage (in volts)

3.2.7 U-VISION / U-VISION+

All the items will be explained in the Local Parameters chapter.

3.2.8 U-PULSER / U-PULSER+

These units have to be connected to a U-Count module.

U-Pulser has a double channel reed switch. A (6) represents the first pulse generator and B (8) represents the second pulse generator. COM (4) is the common wire.

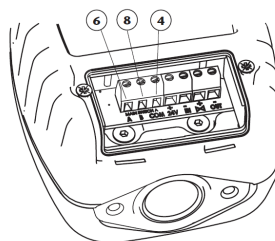

Regarding LED indications and buttons, U-Pulser label indicates the meaning of each one.

U-Pulser+ has no buttons and it has to be connected as per the picture.

3.2.9 U-TANK

These are the main external elements of the U-Tank

1. RGB LED graphic bars.
2. 128x64 backlight LCD display.
3. Keypad.
4. Status LEDs
5. Bypass key switch.



This unit needs external mains power. You have to connect the PSU unit to 240 VAC / 110 VAC - 50 / 60 Hz mains supply. Wiring for this connector must be 3 x 1.5 mm² minimum.

This unit can control up to two tanks with different kind of probes (analogue or contact probes) and the communication has to be made via CANBUS and it can control a general air supply solenoid valve and one air solenoid valve for each pump



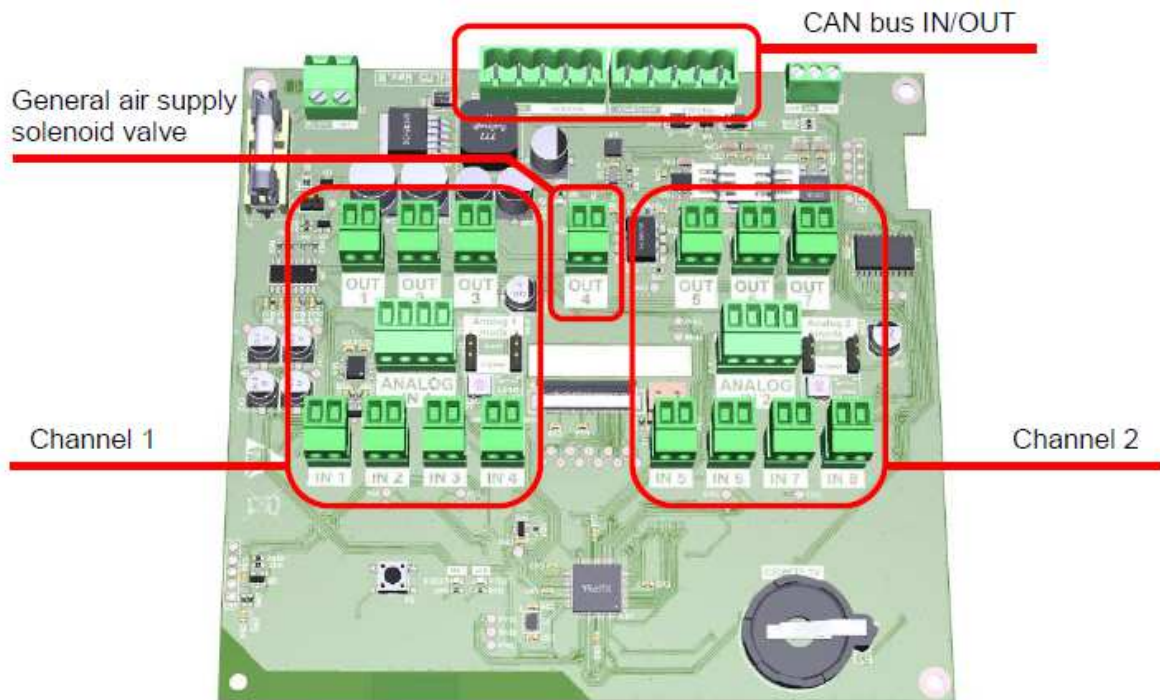

In the attached drawing, Channel 1 indicates the connectors for the Tank 1 and Channel 2 indicates the connectors for the Tank 2

J21 and J22 connectors are both meant to connect the U-Tank unit to the CANBUS network.

No power lines (black/red wires) are required for the operation of this unit.

Connect each wire of the CANBUS cable to the 5 pole male plug (951982) according to the scheme shown.

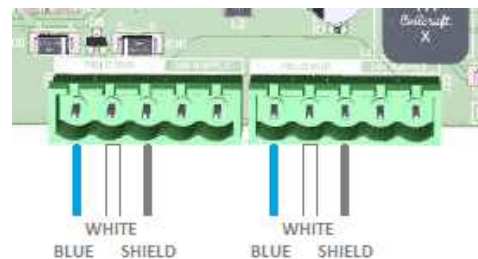

This unit can control up to 2 fluid tanks, each of them will be connected into one channel of the unit. Both channels are symmetrical and has the same functionality (inputs/outputs). If only one tank is connected to the unit, it must be assigned to channel 1.

For each channel, these are the available inputs/outputs. The following picture is for channel 1; channel 2 is identical:

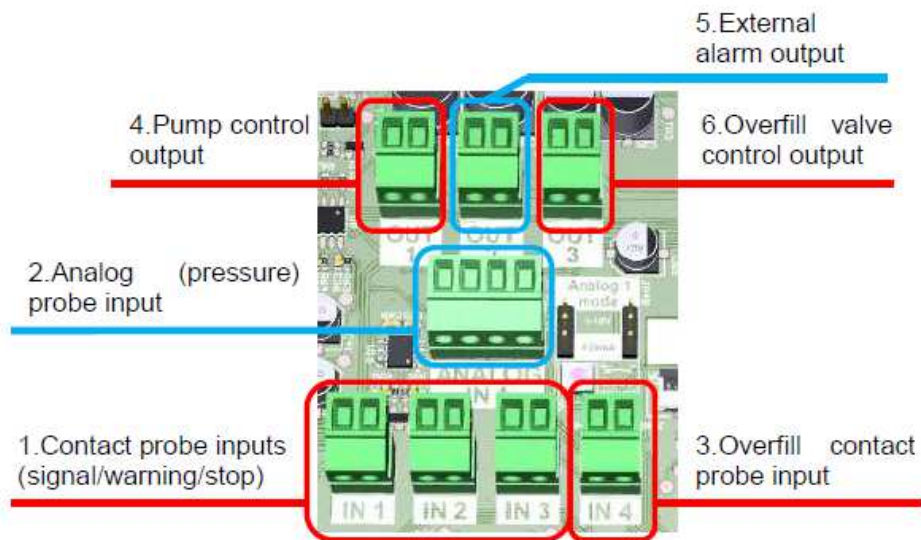

Contact probe inputs (Signal / Warning / Stop)

These three inputs allow connecting up to three contact probes (voltage-free contact type).

Each input has a different logic meaning:

- S1 – IN 1 (SIGNAL): changes the stock level indicated in both the display and the graph bar.
- S2 – IN 2 (WARNING): triggers the warning level into the system and turns into yellow colour the graph bar.
- S3 – IN 3 (STOP): triggers the stop level into the system, turns into red colour the graph bar and gives power to the External Alarm Input.

Note that the three probes must be set at different heights depending on the type of tank being monitored (fresh fluid tank or waste fluid tank):

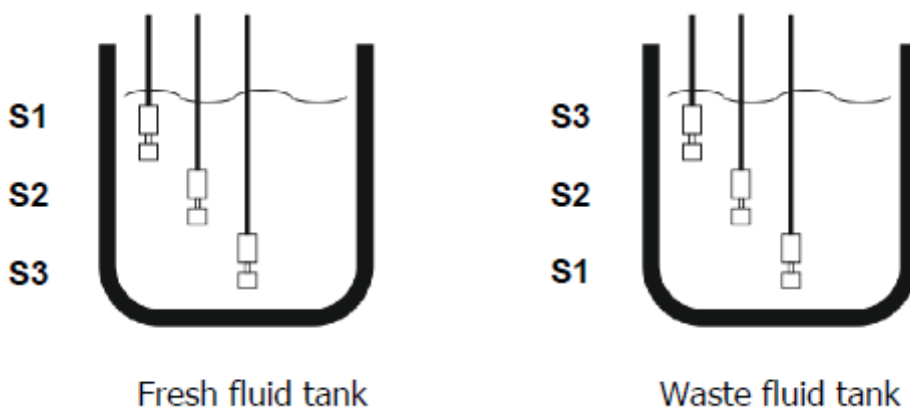

Also, it is possible to use only one or two contact probes: if only one probe is used, it must be connected to S3 (STOP) input; if only two probes are used, they must be connected to S2 (WARNING) and S3 (STOP).

NOTE: Analogue and contact probes cannot be used simultaneously into the same tank.

Analog (pressure) probe input:

This input allows connecting an analogue level probe in order to get in real time an exact measurement of the fluid level inside the tank.

Only barometric level probes are supported.

The probe must be connected as follows (red to +24V, black to IN):

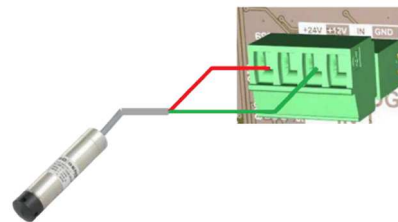

NOTE: Analogue and contact probes cannot be used simultaneously into the same tank.

Overflow input/output

This input allows connecting a voltage-free contact probe (float type or equivalent). Only normally-closed (NC, the electrical contact inside the probe must stay closed when the fluid level is below the probe) switch-type probes can be used.

This input, together with the overflow valve output, is meant as a safety device to prevent overflowing the tank. By setting the overflow probe at the maximum allowed fluid level inside the tank (full tank level), it stops the fluid from entering the tank as soon as the overflow level probe is reached.

NOTE: This input/output is independent from the system, does not require any setup, and will not trigger any warning into the system. It can be used together with both analogue and contact probes.

OUTPUT LOGIC:

Active (24VDC OUT) when the fluid reaches the overflow probe

Inactive (0VDC OUT) when the fluid is below the contact probe.

Pump control output

This output allows controlling the compressed air supply to the pump associated with this tank: when there is an active transaction that requires fluid from the tank, the pump is supplied with compressed air to make it work; and when there is no active transaction requiring fluid from this tank, the pump does not get any compressed air supply and, therefore, is depressurized.

This helps to minimize compressed air leaks and reduces the physical stress of the pump.

OUTPUT LOGIC:

Fresh product

Active (24VDC OUT) while one or more FCU units (U·Valve, U·Valve+, U·Meter, U·Meter+, U·Count) connected to the tank are performing a transaction, and at the same time, the level is not below Stop contact level (S3) or while the unit is in bypass mode.

Inactive (0VDC OUT) when there is no transaction in any of the aforementioned units.

Waste oil

Active (0VDC OUT) when the fluid is below the contact probe.

Inactive (24VDC OUT) when the fluid is in touch with the Stop contact level (S3).

External alarm output

This output is intended to control an external (remote) flash indicator and/or warning buzzer. It is controlled by the system's warning and stop levels (regardless of the type of probes being used): if the warning level or stop level is triggered for this tank, this output becomes active.

OUTPUT LOGIC:

Active (24VDC OUT) when the fluid reaches either the warning or stop level

Inactive (0VDC OUT) when the fluid is above (for fresh fluid tank) or beyond (for waste fluid tank) the warning level.

General air supply solenoid valve:

This output is intended to control the general air supply into the workshop. A time schedule can be set into the U·Track software with the working periods during which the air supply must be available.

Alternatively, this output can be controlled manually from the U·Track (without time schedule).

OUTPUT LOGIC:

Active (24VDC OUT) when the general air status is set to ON (according to the time schedule or by setting it manually), or while the unit is in bypass mode

Inactive (0VDC OUT) when the general air status is set to OFF.

3.2.9.1 STAND BY DISPLAY

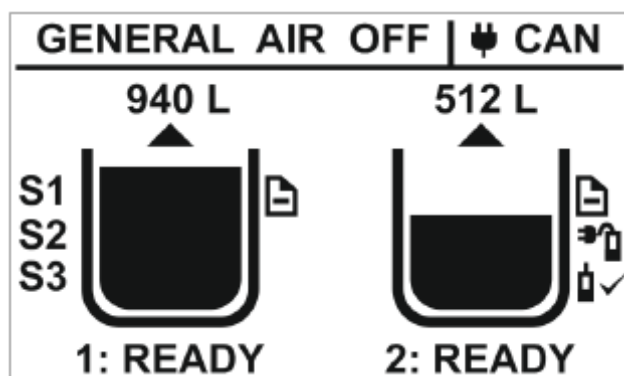

When the unit is in standby mode (the switch key is in "normal" position), the following screen will appear like this.



Several items provide the user with information about the system's status:

The arrow above each tank indicates whether it is a fresh fluid tank (arrow pointing upwards) or a waste fluid tank (arrow pointing downwards).

The  symbol at the right side of each tank indicates that the setup information for the tank has been successfully received from the U·Track software.

The  symbol at the right side of each tank indicates that an analogue probe is currently connected to the analogue input of the tank. If this probe is sending an acceptable value, the symbol  is also displayed.

If the tank has been set to use digital probes, up to three indications (S1, S2, S3) will appear at the left side of the tank, indicating which digital probes have been enabled. Note that the order of the probes changes depending on whether it is a fresh fluid tank (Stop probe/S3 will be at the bottom of the tank) or a waste fluid tank (Stop probe/S3 will be at the top of the tank).

The volume of fluid inside the tank is displayed in real time above each tank, expressed in the units of the system (L for litres, G for gallons). If the tank is using analogue probes, this quantity is the exact volume measured by the unit; if the tank is using digital probes, this quantity is the volume estimated by the U·Track.

Below each tank, the tank number inside the system is displayed (1 to 52), along with the status of the pump control output:

- READY: pump is depressurized and ready for delivering fluid.
- RUNNING: pump is pressurized and delivering fluid to one or more dispensing points.
- STOP: pump is depressurized and is locked from delivering fluid because either the tank is empty (fresh fluid tank) or the tank is full (waste fluid tank).

Also, the fluid level is displayed graphically inside the tank, and through the associated LED graph bar, and will change accordingly with the measured level.

Note that the lighting colour of the graph bar segments will change depending on the status of the tank: if the tank is in "normal" status, the lighting colour will be green; if the tank is beyond "warning" level, the lighting colour will be yellow; and if the tank is beyond "stop" level, the lighting colour will be red.

3.2.10 U·NET

Rear View

- 1.- Ethernet terminal. To be connected to the customer computer network or NEX·U· Wi-Fi[®] router
- 2 / 3.- USB ports (4 units).
- 4.- CANBUS connections.
- 5.- End of Line switch.
- 6.- Wi-Fi[®] antenna.
- 7.- ZigBee[®] antenna.

Inside the U·NET you will find a USB dongle in which a configuration back-up is stored every sunday at 23:59

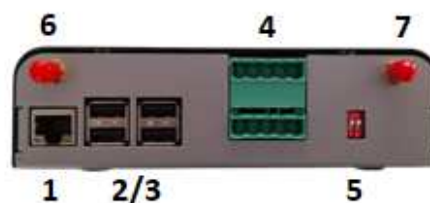

Side View

- 1.- Power input. This is a 5 VDC input but the U·Net has got a transformer to convert mains power (110 VAC or 240 VAC) to 5 VDC
- 2.- HDMI connector. Only for service.
- 3.- Micro USB connector. Only for service.

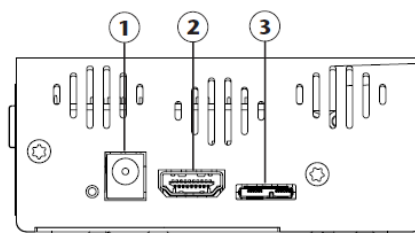

Wiring must be made as shown in the picture.



If two CANBUS connections have to be made, then connect the upper terminal in the same way. In this case, the EOL resistor has to be deactivated (see local parameters chapter)

Regarding LED indications and buttons, U-Net label indicates the meaning of each one.

- 1.- Reset button.
In the event of restarting the U-Net, it has to be pressed.
- 2.- Status Indicator
Power: It indicates if there is power to the unit
Status: It indicates if CANBUS is OK
Online: It indicates if it is ready for working.
RX: Communication Flow to the unit
TX: Communication Flow from the unit

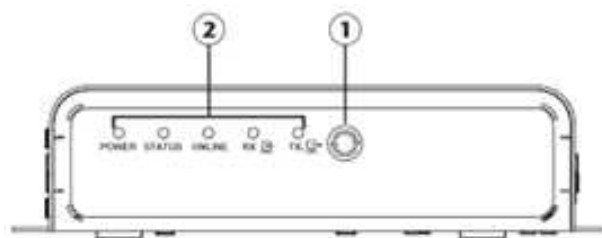

3.2.11 U-CONNECT

Front View

- 1.-Keyboard: Allows to make the unit configuration.
- 2.-LEDs: Shows the state of the unit
- 3.-LCD screen: Shows information for configuration of the unit.

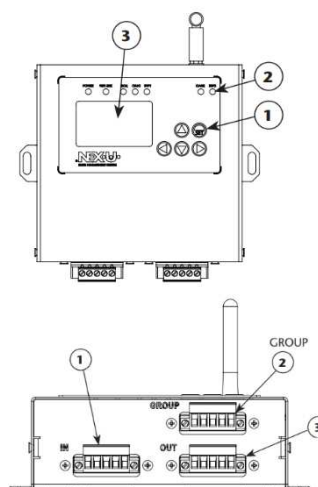

- 1.-Not in use
- 2.-Not in use
- 3.-Communication and power connector.

Wiring must be made as shown in the picture.

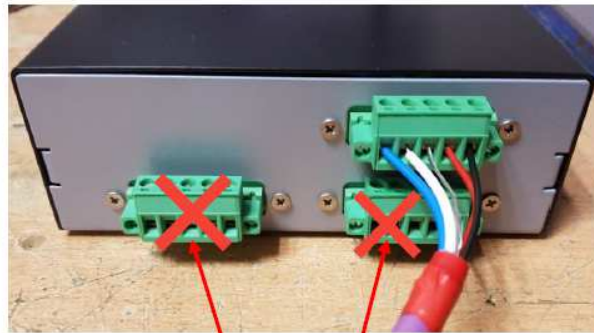

NOT USED

3.3 FIXING OF THE ELEMENTS

3.3.1 U-DAT / U-DAT+

The unit can be fixed with the 4 VESA 100 holes placed in the back of the case (1).

The attachment holes (2) are used in case of equipment flush installation.

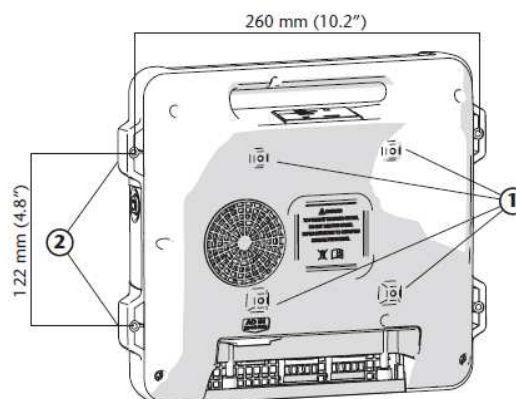

3.3.2 U-POWER / U-POWER+

The unit can be fixed to the wall or others fixtures of the installation by means of the front fixations (1).



3.3.3 U-VALVE / U-PULSER / U-PULSER+

The unit can be fixed to the wall or others fixtures of the installation by means of the front fixations (1) or the four threaded holes (2) placed on the back of the unit.

This equipment is intended to be installed directly in the distribution pipeline. The unit has a F1/2" connection at both inlet and outlet. Prior to installing the equipment, notice the location of the inlet fluid connection indicated as "IN" (3). It is mandatory to respect the flow direction for proper operation.

Avoid installing the unit between rigid connections to prevent efforts transmission of the pipeline. It is recommended to install a pressure relief system on the line to prevent damage from thermal expansion.

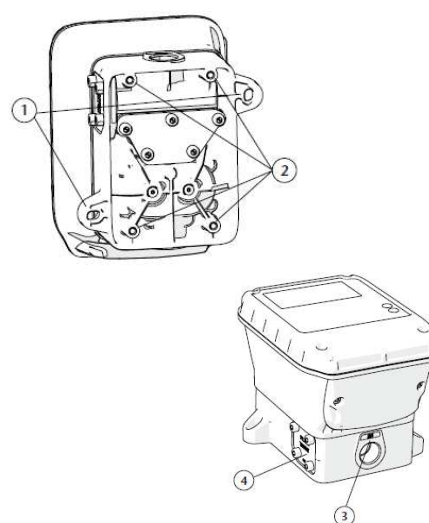

The unit incorporates an easy access mesh-40 strainer (4) to prevent damage from dirt or solid particles carried by the fluid.

WARNING! Do this operation before installing the unit in its location and with the power source disconnected.

It is mandatory to respect the flow direction marked on the input and output connections, such as “IN” and “OUT”, otherwise the equipment will not work. If due to the configuration of your installation it is unavoidable that the screen is reversed, you can rotate it following the procedure described below.

1. Loose the screws (1) and leave on one side the front cover (2). Be careful that neither the electronic board nor the wiring is damaged. (fig. 3).
2. Loose the screws (3) that attach the plastic housing (4) (fig. 4).
3. Rotate 180 degrees the housing (4) and attach it again using the screws (3) loosen previously. Notice that only 3 of them are now needed (fig. 5).
4. Place the front cover (2) in its right position and fix it by means of the screws (1) (fig. 6).

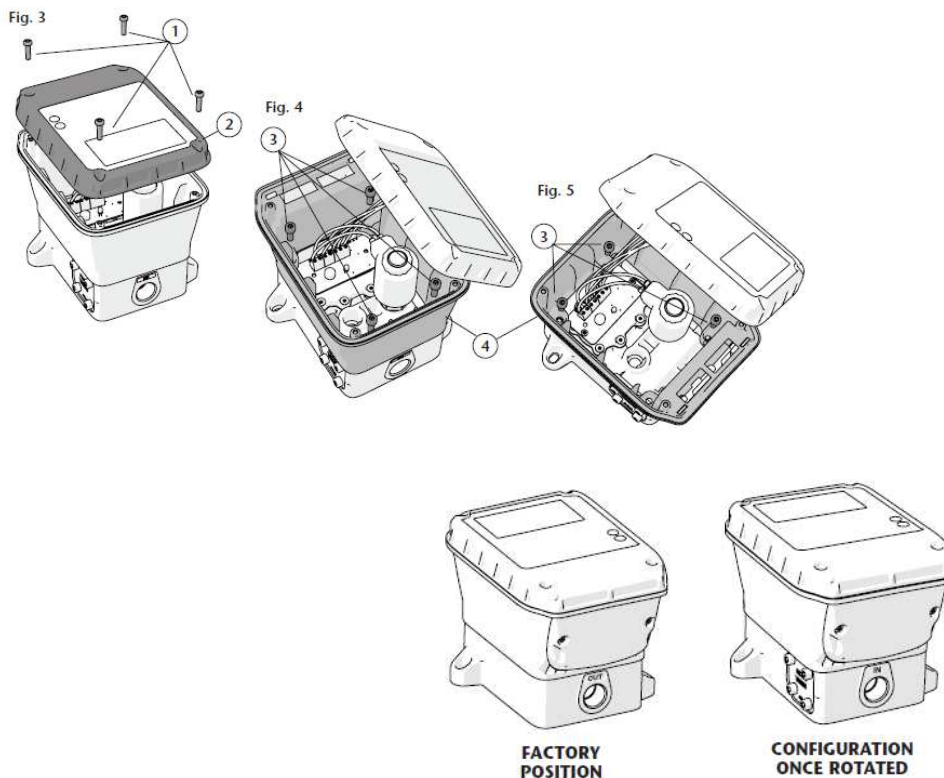

3.3.4 U-COUNT / U-VIEW

The device attachment can be done through the blind holes (1) by using 4 mm diameter self-tapping screws. The attachment holes (2) are used in case of flush mount installation by using the screws supplied.

If required, the equipment can be fixed from its inner part following the next procedure:

1. Remove the screws (3) and remove the front cover (4).
2. Remove the plugs (5).
3. Fix the back cover of the equipment (6), previously wired, with 2 screws (7).
4. Wire the electronic board, reassemble the front cover (4) and fix the screws (3).

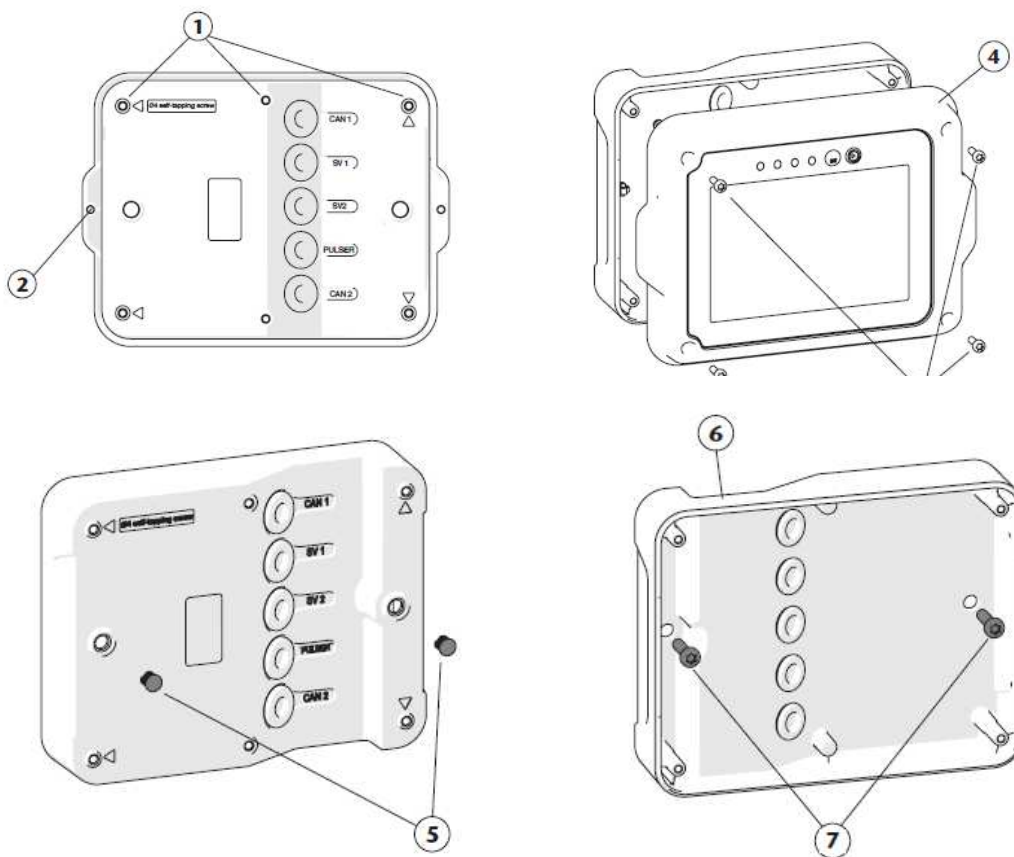

3.3.5 U·METER / U·METER+

This equipment is designed to be installed directly in the distribution pipe line. The meter has a F1/2" connection at both inlet and outlet. It also includes an inlet flange and an outlet flange with seating for an O-ring seal.

Avoid installing the unit between rigid connections to prevent efforts transmission of the pipeline.

It is recommended to install a pressure relief system on the line to prevent damage from thermal expansion.

To prevent damage from dirt or solid particles carried by the fluid is recommended the installation of a 200-mesh strainer at the unit inlet.

It is advised to install the solenoid valve associated to the U·Meter / U·Meter+ at the unit inlet. Do not install the solenoid valve at the unit outlet to avoid the unit being pressurized when the valve is closed.

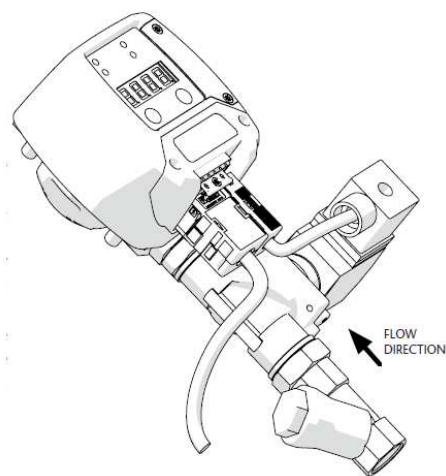

3.3.6 U·VISION / U·VISION+

Follow the next procedure in order to install the U·Vision unit on a control gun:

1. Mount the extension outlet (1) if it is not already attached.
2. In the case that the control gun has the plastic cover (2) mounted, remove it by means of a screwdriver or similar tool. The cover is pressure mounted, it should be easily removed. If the flange cover is mounted, remove it as well.
3. Slide the U·Vision / U·Vision+ unit (3) through the extension outlet (1) until it remains properly fitted onto the flange.
4. By means of the nut, screw and washer kit (4) provided, attach the unit to the flange as indicated in the figure.

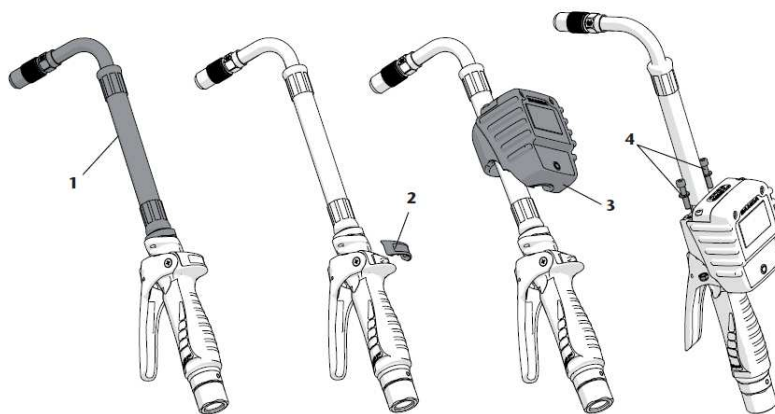

3.3.7 U-TANK

The U-Tank fixation to the elements of the installation can be done through the holes (1) by means of a 4 mm self tapping screw.

In case that this attachment cannot be done to inaccessibility, 4 screws can be fixed from the inner of the case through the holes (2)

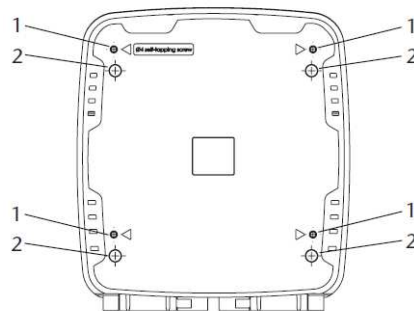

3.3.8 U-CONNECT

The U-Connect fixation to the elements of the installation can be done through the holes at the sides.

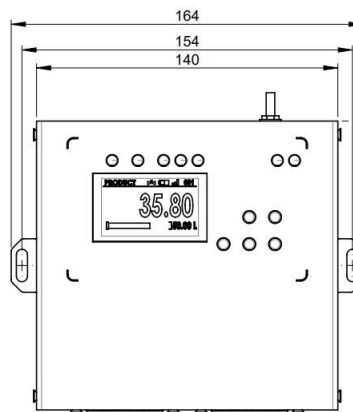
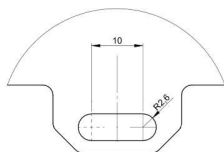

3.3.9 U-LINK

Mount the non-drip nozzle with the 1/2" bonded seal provided (1). Tighten the nozzle nut (1a) firmly to prevent leakage. If using a rigid nozzle, first tighten the nut (1b), place in proper position the nozzle tube (2) and then tighten the nut (3) to secure it.

Before connecting the hose to the gun, you must assemble the swivel cover (4) into the hose (5). This cover is compatible with 1/2" hoses. Depending on the hose end type (6) it may be necessary to open the groove at the swivel cover end to allow it to enter through the hose fitting.

To connect the hose, hold the hose end (6) stationary while turning the swivel end (7) until the desired tightness is achieved.

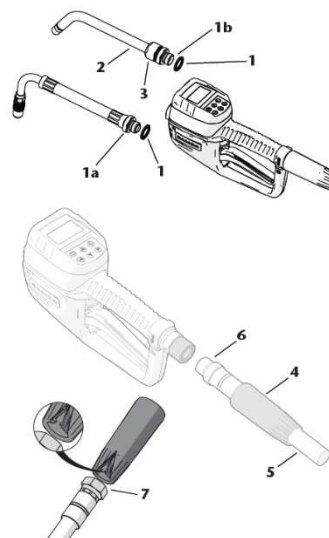

3.4 NETWORK CABLING

NEX·U· cabling has five wires (BLUE / WHITE / SCREEN / RED / BLACK). Although is not compulsory to follow this sequence, it is highly recommended to do so in order to follow this manual.

Following international conventions, blue / white and screen are used for transferring information and red / black are used for supplying power (in our case 24 VDC)

Not in all cases, all the elements must be powered up by the network. In some of the elements, power comes from external source. As a summary

- U·Dat / U·Dat Power+: 110 VAC / 240 VAC from customer power electric network.
- U·Power / U·Power+: 110 VAC / 240 VAC from customer power electric network.
- U·Valve: 24 VDC from NEX·U· network.
- U·Count: 24 VDC from NEX·U· network.
- U·View: 24 VDC from NEX·U· network.
- U·Meter/ U·Meter+: 24 VDC from NEX·U· network.
- U·Vision / U·Vision+: 24 VDC from NEX·U· network.
- U·Pulser / U·Pulser+: 24 VDC from NEX·U· network.
- U·Tank: 110 VAC / 240 VAC from customer power electric network.
- U·Link: 4 x 1.5 VDC AA batteries
- Network Extender: 240 VAC from customer power electric network.
- U·Net: 110 VAC / 240 VAC from customer power electric network.
- U·Connect: 24 VDC from NEX·U· network.

Units that are powered up by the customer power electric network, transfer power to the units that are powered by the NEX·U· network. Therefore, DO NOT POWER UP TWO UNITS AT THE SAME TIME FROM DIFFERENT 110 VAC / 240 VAC SOURCES.

As a guideline, the maximum length of a wiring coming from a 110 VAC / 240 VAC source must be:

$$\text{Max Lenght} = \frac{120}{\text{No. of Units}}$$

$$2 < \text{No. of Units} < 8$$

3.4.1 CABLING FROM U-DAT / U-DAT POWER+ TO U-VALVE

In the attached picture you can see the wiring connection.

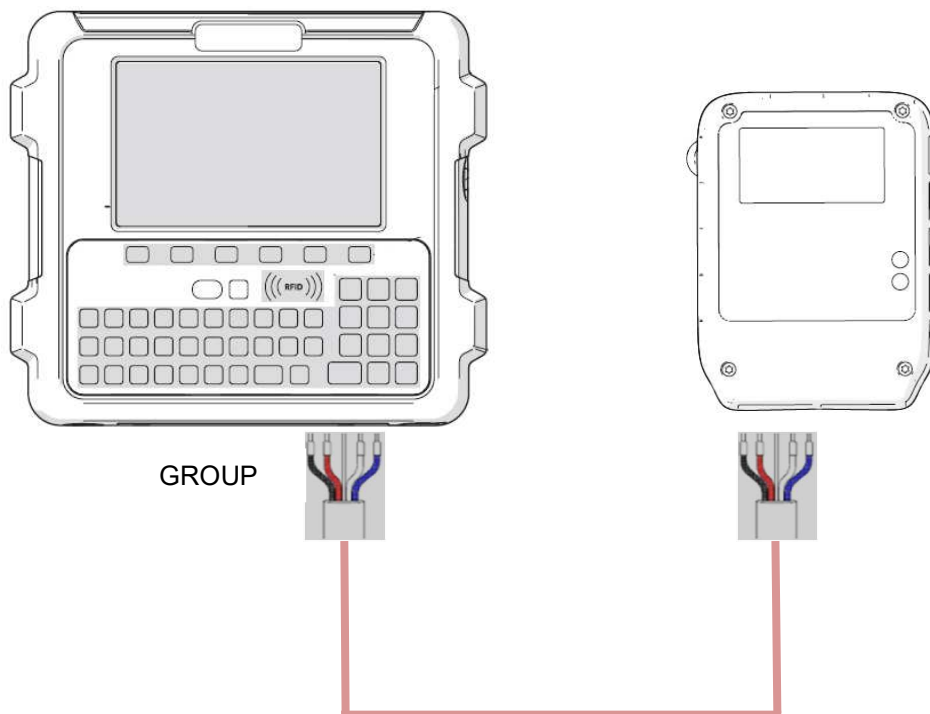

WARNING: DETAIL OF CABLE PEELING

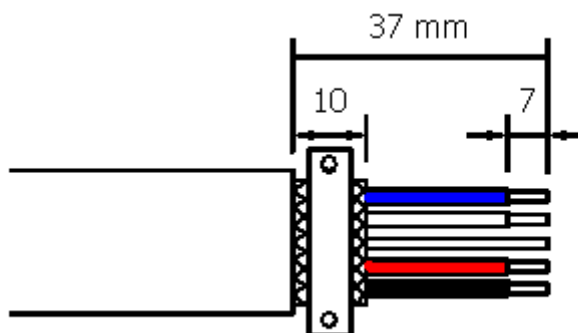

3.4.2 CABLING U-VALVE / U-METER / U-METER+ TO U-VALVE / U-METER / U-METER+

In the attached picture you can see the wiring connection

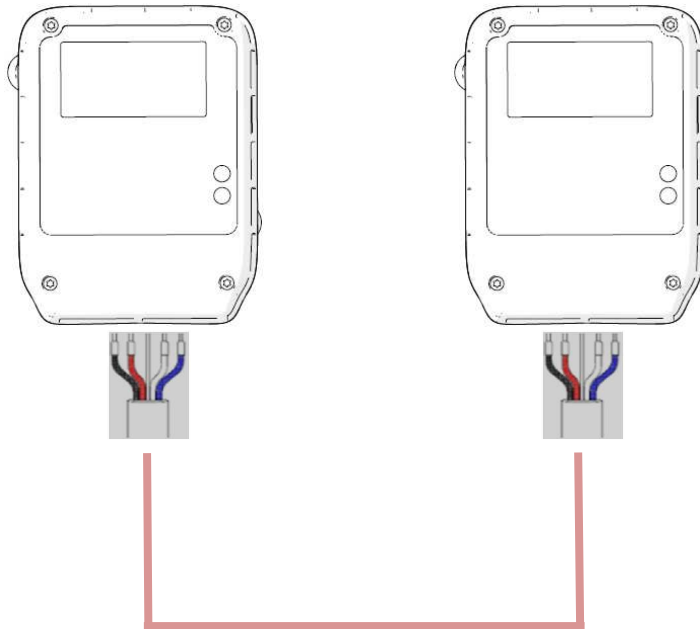

In this case, power is transferred from U-Valve to U-Valve. That is why five wires are connected. This scheme is identical for U-Meter / U-Meter+, U-Valve to U-Meter and all the combinations.

WARNING: DETAIL OF CABLE PEELING

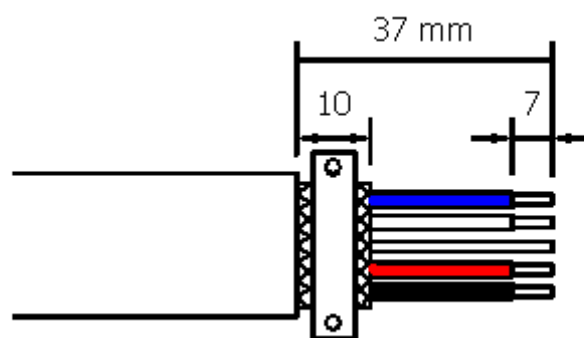

3.4.3 CABLING FROM U-DAT / U-DAT POWER+ TO U-DAT / U-DAT POWER+

In the attached picture you can see the wiring connection

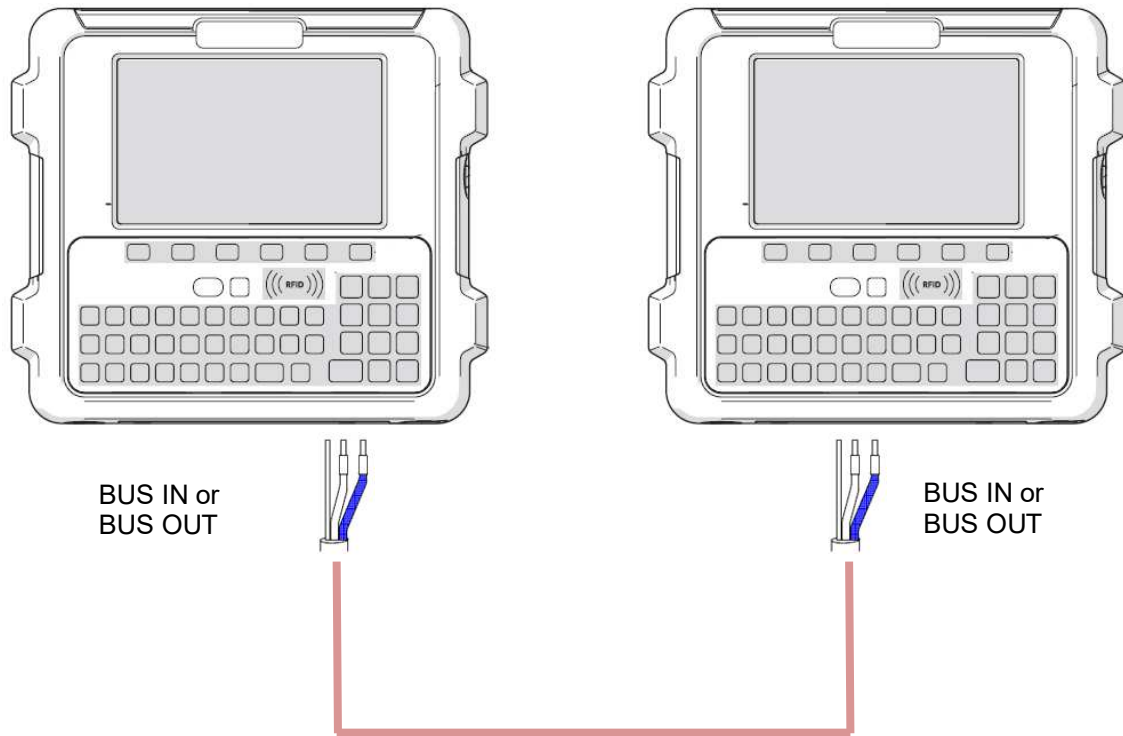

You can see that, as previously told, red and black wires must not be connected since there is an external power source for both items.

WARNING: DETAIL OF CABLE PEELING FOR U-DAT / U-DAT+ CONNECTION.

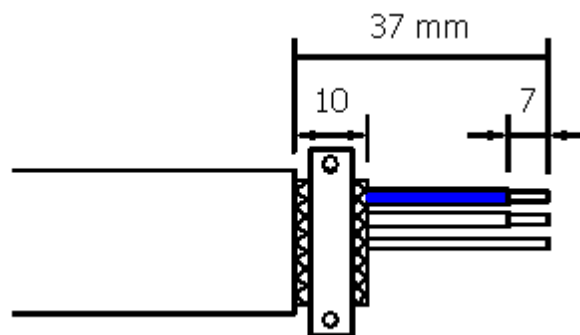

3.4.4 CABLING FROM U·NET TO U·DAT / U·DAT+

In this case, as both units are powered up by an external source, the only wire that must be connected are SHIELD / WHITE / BLUE (Communication)

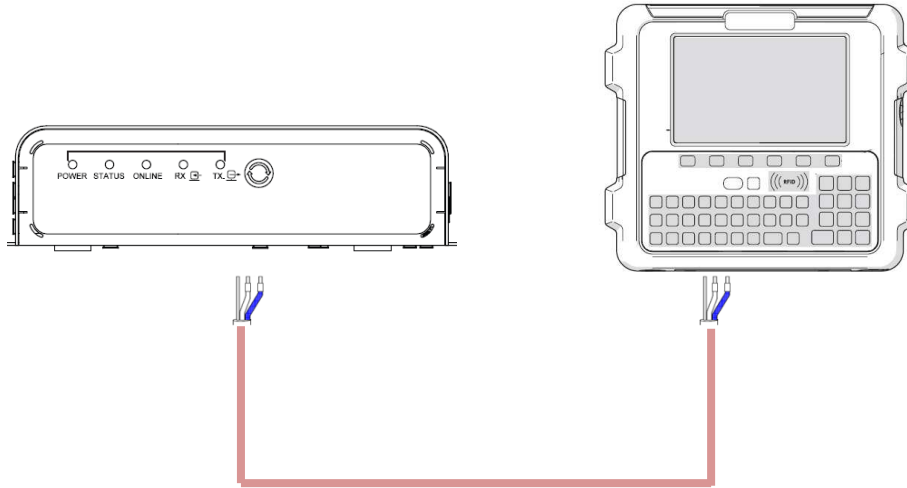

3.4.5 CABLING FROM U·TANK TO U·DAT / U·DAT+

In this case, as both units are powered up by an external source, the only wire that must be connected are SHIELD / WHITE / BLUE (Communication)

3.4.6 CABLING FROM U·VALVE / U·METER / U·METER+ TO U·CONNECT

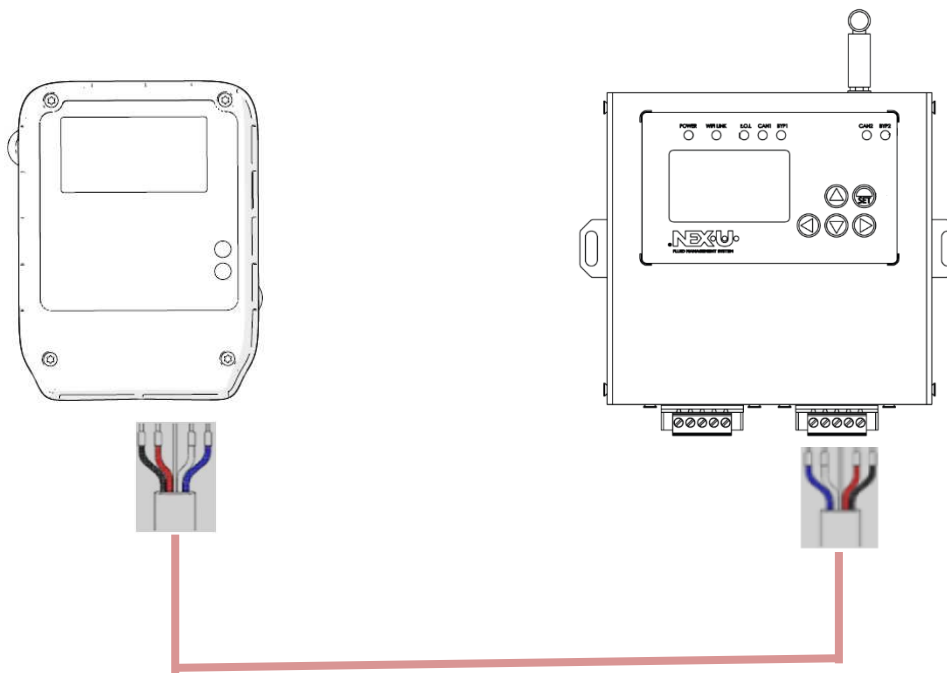

3.4.7 POWER SUPPLY CONNECTION

This item applies to all the externally powered units, that is to say

- U·Dat / U·Dat+
- U·Power / U·Power+
- U·Tank
- U·Net
- Network Extender

The devices are configured for 110 VAC / 240 VAC mains power.

A stand-alone 3x1.5mm² rigid cable connected to the circuit breaker is to be used. No electrical derivations from the circuit breaker to other devices must be connected.

The use of a differential switch 300 mA of 10 Amperes is highly recommended.

Note: This equipment includes metallic parts that the user easily gets in contact with. These elements may accidentally be crossed with hazard current. **AN INSTALLATION MUST THEREFORE NEVER BE POWERED UP WITHOUT PREVIOUS ASSURANCE THAT ALL EARTH CONNECTIONS, LINE CONNECTIONS, ETC. HAVE BEEN DONE CORRECTLY.**

The U·Link needs 4 x 1.5 VDC AA batteries.

The gun is supplied without these batteries installed, follow the procedure described below for installation or replacement:

Remove the rubber cover (1) and then loosen the screws (2). Remove the battery housing cover (3).

Install the supplied batteries (4) or equivalent batteries (see technical specifications) according to the polarity indicated in the battery compartment (5).

Place again the cover (3) and tighten the screws (2).

Finally, mount the rubber protector (1).

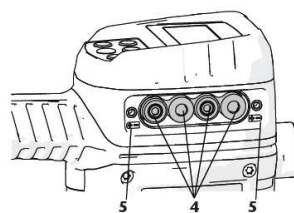
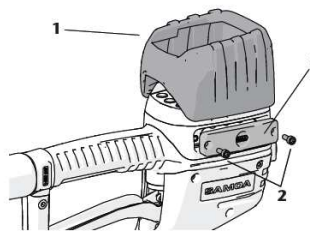

4 SETTING PROCEDURE AND DEFINITION OF THE PARAMETERS

4.1 SETTING PROCEDURE

When the whole system is connected the following steps have to be followed to start the system up:

1. Set the **local parameters** in each one of the installation components (U·Dat / U·Dat Power+, U·Valve, U·Count, U·Vision, etc.). These local parameters are: address, End of Line resistor and Filter CAN (this one only for U·Dat / U·Dat Power+)
2. Set the **global parameters** of the installation from the U·Track, these parameters define the hose reels, tanks, language, scenario of data introduction, etc.
3. Make the probes **calibration** if U·Tank is installed.
4. **Send** this **configuration** of the global parameters from the U·Track to the rest of the system.

4.2 ADDRESS DEFINITION

Each component on the network must have an address.

Each component must have an address that is unique in its family. There are five types of families:

- Family I. U·Dat / U·Dat Power+
- Family II. U·Valve, U·Valve+, U·Count, U·Meter / U·Meter+, U·Link
- Family III. U·View.
- Family IV. U·Tank.
- Family V. U·Connect.

The numeration in each family goes from 1 to 127, without leaving EMPTY SPACES:

- The U·Dat / U·Dat Power+ will have the following numeration: 1, 2, 3, etc...
- The U·Valve, U·Count, U·Meter / U·Meter+, U·Link: 1, 2, 3, etc...
Note: In the case of this family, the address corresponds to the number of a hose reel.
- The U·Views are numbered with 1, 2, 3 etc...
- The U·Tanks are numbered with 1, 2, 3 etc...
- The U·Connect are numbered with 1, 2, 3 etc...

Two units in the same family must not have the same address.

4.3 END OF LINE (EOL) RESISTORS

In this case, there is a main CANBUS line (which is the one that connects the U·Dat / U·Dat Power+ / U·Tank / U·Net and the secondary CANBUS lines that connect the U·Dat / U·Dat Power+ with the dispensing elements (U·Valve / U·Meter / U·Meter+ / U·Count / U·Connect and U·View as well))

The main CANBUS line will require EOL resistor at both ends and the secondary CANBUS will only require EOL resistor at the end which is NOT the U·Dat / U·Dat Power+ since the U·Dat / U·Dat Power+ has got a preset EOL resistor.

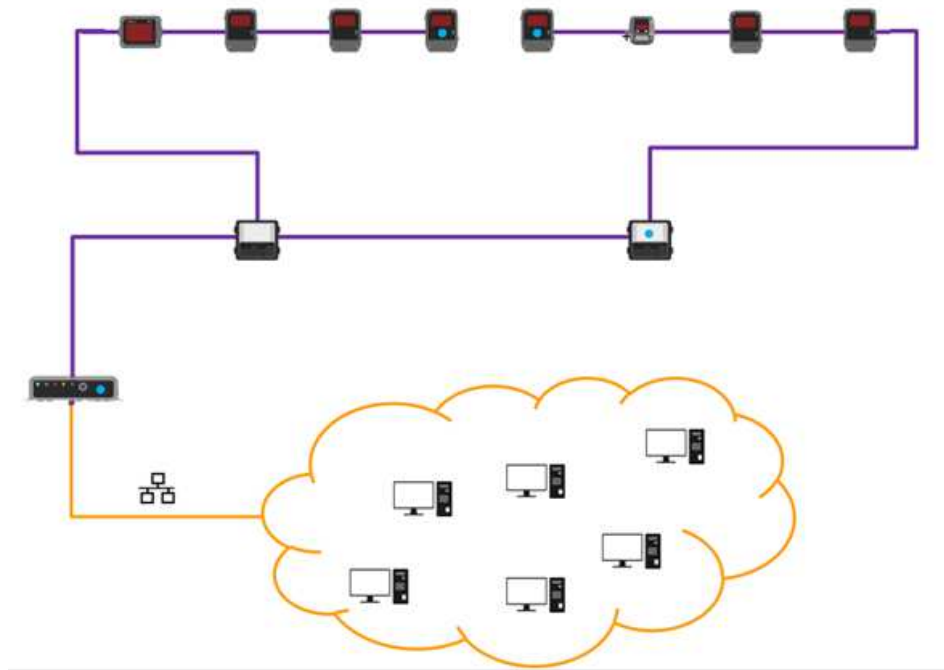

You will find a 120 Ohm resistor with the U·Dat / U·Dat Power+. That is an external EOL resistor and it is highly recommendable to install it in the last U·Dat / U·Dat Power+ of the main CANBUS between white and blue wires. This is a precautionary measure since if the U·Dat / U·Dat Power+ gets damaged, maybe the software EOL is disabled and the main CANBUS can go down.

4.4 LOCAL PARAMETERS SETUP

4.4.1 LOCAL PARAMETERS SETUP ON A U-VALVE / U-VALVE +

Before the unit can operate, a few configuration steps for local parameters must be accomplished:

1. Connect the power to the unit. It will appear briefly on the display the current firmware installed and then the hose reel address is shown (by default "001").
2. Press and hold F1 and F2 buttons until it is shown "SET" in the display.
3. The display shows a number that increases progressively from 001. This number is the hose reel number linked to the unit. Once that the desired number is shown, press briefly F2 button. NOTE: If it is needed to restart the hose reel number to "001", press briefly F1 button.
4. Now the unit shows the message "EoL" (end of line), followed by "0" or "1". This parameter allows indicating whether the unit is end of line in the CANBUS (1) or it is an intermediate unit (0). Change the adjustment pressing the F1 button briefly and press F2 button to confirm.

NOTE: If the unit is configured as end of line, the end of line blue led lights up to ease the identification of bus endings.

5. Now the unit shows the message "BLE" (Bluetooth[®]), followed by "0" or "1". This parameter allows indicating whether the Bluetooth[®] sender/receiver unit is either enabled or not. Change the adjustment pressing the F1 button briefly and press F2 button to confirm.
6. Having reached this point, the unit stores in its memory all the parameters introduced and it is restarted with these new parameters.

NOTE: In the case that the unit is restarted before reaching this last step (due to a power loss or whatever reason), the parameters introduced will not be stored in the unit

If you are installing a U-Valve+ (Wi-Fi[®] enabled), the Wi-Fi[®] configuration must be made. There are two options for this. With PC software and with Android app.

WARNING: In all the cases, port 2503 in the modem must be open during the configuration process and the normal U-Valve+ operation

To make an easier configuration, the Wi-Fi[®] module U-Valve+ MAC address is supplied with each U-Valve+. This will make the router configuration easier to link it to a fixed IP.

PC Software

Open ConfigNexu.exe and change language to English (upper right side of the screen)

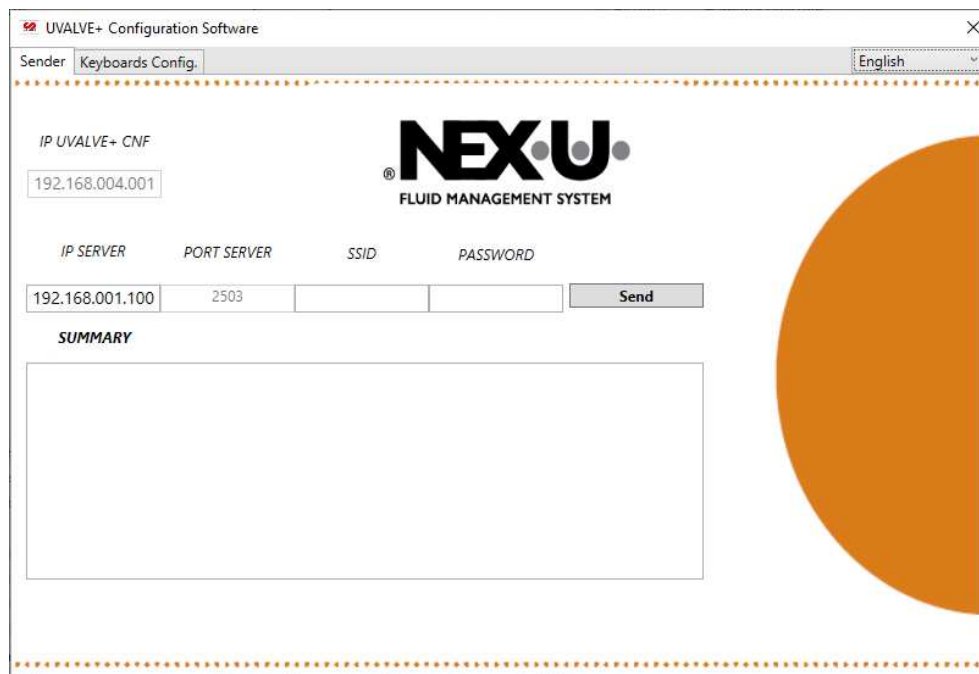

In a PC with Wi-Fi® connection, you need to open the available networks and look for U·Valve 00X (being 00X the U·Valve number that needs to be configured). In the example U·Valve 25



Disable the option Connect automatically and then press Connect. The system will ask for a password. Enter 123456789

Once it is connected to the U·Valve+ you will see that a “C” appears on the display.

Go to ConfigNexu.exe again and insert the following data in the U·Valve+ tab

- IP SERVER: U·Net IP (this data must be provided by the customer)
- SSID: Name of the Wi-Fi® network
- Password: Password of the Wi-Fi® network

When everything is set properly, press “Send” The “C” letter on the U·Valve+ display and the LEDs should flash.

Wait until “OK” appears on the U·VALVE + display. It will restart automatically.

WARNING: If there was an error in the process, U·Valve+ will display “ERR” on display and restart automatically. In this case, try to redo the entire process after reviewing the network parameters.

Once it is connected, the Wireless icon and the number of the U·Valve will appear in the U·Valve display. It means that the U·Valve is connected and ready to work.

Android app

For the U·Valve configuration from tan Android phone, there is an App called Usetup that can be supplied by your local NEX·U· distributor.

In an Android phone with Wi-Fi ® connection, you need to open the available networks and look for U·VALVE+CNF-XX (being XX the U·Valve number that needs to be configured). In the example U·Valve 5



Disable the option Connect automatically and then press Connect. The system will ask for a password. Enter 123456789

Go to the Usetup App and you will get into this screen

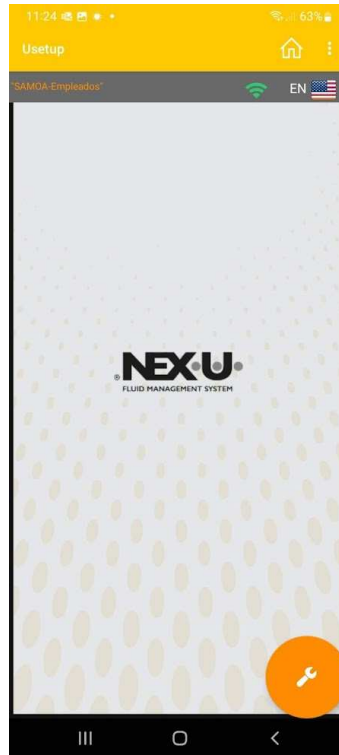

The Wi-Fi® sign has to be in green colour and the connected network and the connected network has to be the U·VALVE one (in the picture you see SAMOA-Empleados but you will have to see U·VALVE+CNF-XX

Then press this icon  and it will take you to the configuration screen

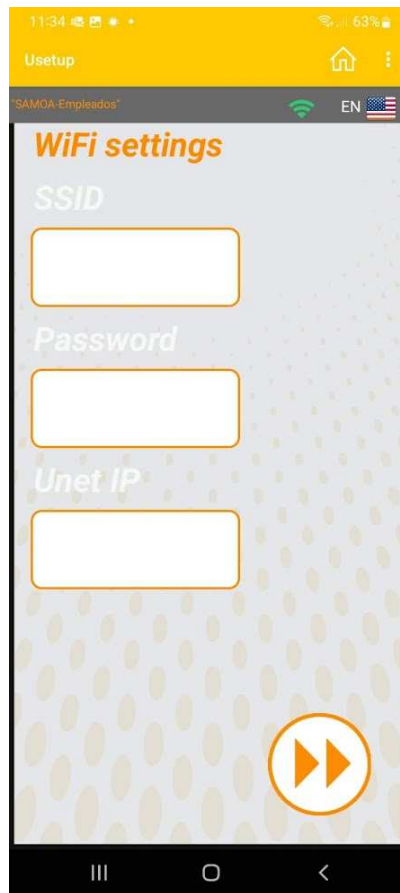

- SSID: Name of the Wi-Fi ® network
- Password: Password of the Wi-Fi ® network
- U·Net IP: U·Net IP (this data has to be provided by the customer)

When everything is set properly, press 

The “C” letter on the U·Valve+ display and the LEDs should flash. Wait until “OK” appears on the U·VALVE + display. It will restart automatically.

WARNING: If there was an error in the process, U·Valve+ will display “ERR” on display and restart automatically. In this case, try to redo the entire process after reviewing the network parameters.

Once it is connected, the Wireless icon and the number of the U·Valve+ will appear in the U·Valve+ display. It means that the U·Valve+ is connected and ready to work.

4.4.2 LOCAL PARAMETERS SETUP ON A U·METER / U·METER+

Before the unit can operate, a few configuration steps for local parameters must be accomplished:

1. Connect the power to the unit. It will appear briefly on the display the current firmware installed and then the hose reel address is shown (by default "001").
2. Press and hold F1 and F2 buttons until it is shown "SET" in the display.
3. The display shows the message "A" (address) followed by a number that increases progressively from 001. This number is the hose reel number linked to the unit. Once that the desired number is shown, press briefly F2 button. NOTE: If it is needed to restart the hose reel number to "001", press briefly F1 button.
4. Now the unit shows the message "EoL" (end of line), followed by "0" or "1". This parameter allows indicating whether the unit is end of line in the CANBUS (1) or it is an intermediate unit (0). Change the adjustment pressing the F1 button briefly and press F2 button to confirm.

NOTE: If the unit is configured as end of line, the end of line blue led lights up to ease the identification of bus endings.

5. In the next screen the display shows the message "Dir." followed by an animated bar graphic. This parameter allows setting the fluid flow direction through the unit.
6. Press F1 button to set flow direction so that the animated bars movement matches the fluid flow in the unit. Press F2 button to confirm.
7. Having reached this point, the unit stores in its memory all the parameters introduced and it is restarted with these new parameters.

NOTE: In the case that the unit is restarted before reaching this last step (due to a power loss or whatever reason), the parameters introduced will not be stored in the unit

4.4.3 LOCAL PARAMETERS SETUP ON A U·LINK

Before the unit can operate, a few configuration steps for local parameters must be accomplished:

1. Start the unit up by pressing any UP/DOWN keys.
2. Press ENTER and CANCEL buttons until the SETUP menu is displayed (it takes about 3 secs). The SETUP screen will appear.
3. Pressing the UP/DOWN buttons allows navigation through menu functions.
4. Go to LOCAL SETUP and press ENTER
5. Pressing the UP/DOWN buttons, set the U·Link local address

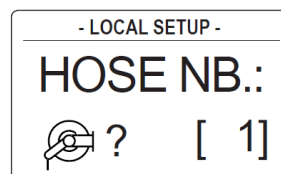
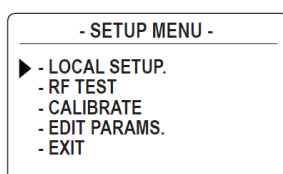
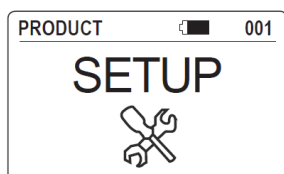

4.4.4 LOCAL PARAMETERS SETUP ON U·DAT / U·DAT POWER+

Before the unit can operate, a few configuration steps for local parameters must be accomplished:

Turn on the device. After a while, the home screen will show up. Regardless of the menu shown on screen, after a period of inactivity, the application will come back to the home screen.

From the home screen, press the shortcut key  associated with the unlock icon to access the main menu.

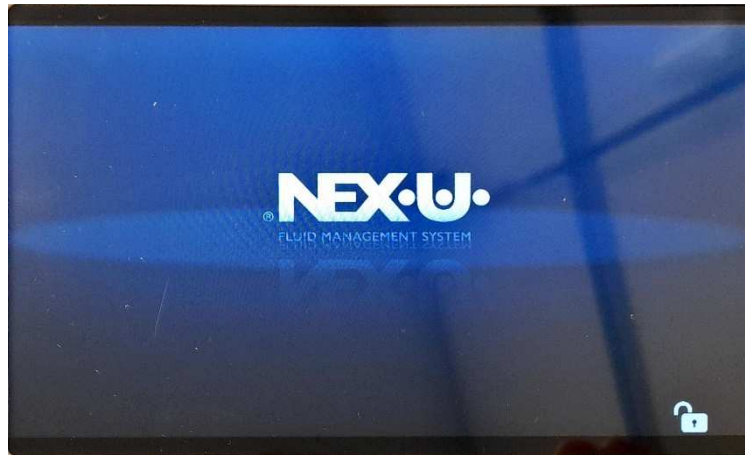

In the upper part of this screen, you will see the selected language, the U·DAT identifier, date and time and the CANBUS indicators (MAIN and GROUP) as well as the End of line (EOL) state.



In the lower part of the screen, you will find the icons for dispensing () , stocks () , transactions () and configuration menu ()

Choose and configuration menu ()

To access the configuration menu, two consecutive access codes are required. The first one is (four dots). Press ENTER and then the system will ask for another one which is **NEXU**. Press ENTER again. The main configuration parameters of the device are displayed on the screen once the codes have been entered.



In this screen the following parameters have to be set:

Address: U·Dat / U·Dat Power+ number starting from No. 1. Two units cannot have the same address

Bus mode: There are three different modes depending on the topology of the wiring in the installation

- Dual: Connected wiring to BUS IN and/or BUS OUT. Connected wiring to GROUP
- Main: Connected wiring to BUS IN and/or BUS OUT. Not connected wiring to GROUP
- Group: Not connected wiring to BUS IN and/or BUS OUT. Connected wiring to GROUP

EOL: This parameter allows indicating whether the unit is end of line in the CANBUS (ON) or it is an intermediate unit (OFF).

Then press SAVE

Printer: Just in case you want to link a Bluetooth® NEX·U ticket printer, please click on CONNECT. A new screen will appear and the possible printers will appear. If no printers appear, please click on SCAN. Once you have found the desired printer (supplied by your local distributor) please click on the printer and it will be linked to the system.

Language: You can choose several languages. Just choose the desired one, press ENTER

Calibration: Please check chapter 12

Info: You will find three options

- Select Product: When the transaction is prepared, the product is requested and then only the hose reels with that product are shown. Then quantity is requested.
- Select Reel: When the transaction is prepared, the hose reel is requested as a first data. Then quantity is requested.
- U·NET IP: If you press that button, the U·NET fixed IP is shown on screen.

Database: You will find six options

- Factory Reset: If you click on that, the U·DAT will go back to default settings
- Get Users: If you click on that, the U·DAT will upload all the users which are in the U·TRACK
- Users: If you click on that, the U·DAT will show the users in the U·DAT
- Get Info: U·DAT Internal information. For Service purposes
- Remove transactions: If you click on that, the U·DAT will delete the list of transactions that are stored in its memory
- Remove transactions in progress: If you click on that, the U·DAT will delete the list of transactions that are being made in that moment.

Debug: This is a soft reset of the U·Dat / U·Dat Power+. Not available for installation. Only for developer access.

There is a hidden menu below Debug option. You can reach it by pressing the touch screen on the red square.

This one allows you to enable either an RFID or the iButton.

For setting RFID you have to write FREADER40 and then press OK

For setting iButton you have to write FREADER08 and then press OK



4.4.5 LOCAL PARAMETERS SETUP ON U·COUNT

Before the unit can operate, a few configuration steps for local parameters must be accomplished:

1. Connect the power to the unit. It will appear briefly on the display the current firmware installed and then the hose reel address is shown (by default "001").
2. Press and hold SET and Enter buttons until it is shown "SET" in the display.
3. The display shows the message "A" (address) followed by a number that increases progressively from 001. This number is the hose reel number linked to the unit. Once that the desired number is shown, press briefly Enter button. NOTE: If it is needed to restart the hose reel number to "001", press briefly SET button.
4. Now the unit shows the message "EoL" (end of line), followed by "0" or "1". This parameter allows indicating whether the unit is end of line in the CANBUS (1) or it is an intermediate unit (0). Change the adjustment pressing the F1 button briefly and press F2 button to confirm.

NOTE: If the unit is configured as end of line, the end of line blue led lights up in order to ease the identification of bus endings.

5. Now the unit shows the message "BLE" (Bluetooth®), followed by "0" or "1". This parameter allows indicating whether the Bluetooth® emitter/receiver unit is either enabled or not. Change the adjustment pressing the F1 button briefly and press F2 button to confirm.
6. Press F1 button to set flow direction so that the animated bars movement matches the fluid flow in the unit. Press F2 button to confirm.
7. Having reached this point, the unit stores in its memory all the parameters introduced and it is restarted with these new parameters.

NOTE: In the case that the unit is restarted before reaching this last step (due to a power loss or whatever reason), the parameters introduced will not be stored in the unit.

4.4.6 LOCAL PARAMETERS SETUP ON U-VIEW

Before the unit can operate, a few configuration steps for local parameters must be accomplished:

1. To Access the configuration menu, press and hold both the SET and ENTER buttons simultaneously until the display shows "LOCAL SETUP"
2. Then, "ADD" is displayed on the screen to indicate that the local address can be set. Automatically a counter is displayed. The count is incremented from one to 126. When the desired address number is displayed, press ENTER to confirm the number. If you want to reset the counter, press SET.
3. Once the address is confirmed, "E.O.L" is displayed on the screen to set the end of line resistor. "ON" (led "E.O.L" on) or "OFF" (led "EOL" off) is displayed according to the last saved status. To change the status, press the "SET" button and then press ENTER to confirm.
4. "MODE" is displayed on the screen to set the display mode during a transaction. To change the mode, press SET until the desired mode, "STD" (standard) or "XXL" are displayed. Once the mode is set, press "ENTER" to confirm.
5. "OK!" is displayed on the screen and the unit restarts showing the standby screen.

4.4.7 LOCAL PARAMETERS SETUP ON U·VISION

This unit can be paired with a U·Meter+, U·Valve, U·Valve+ or U·Count unit.

Pressing the power button shows the start screen during a short time. In the bottom left screen it is shown the U·Vision firmware.

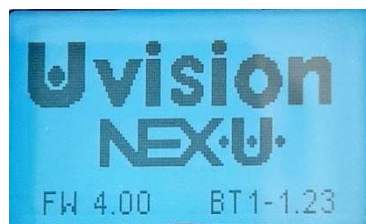

Then the unit will try to link showing the connecting screen. This screen will disappear after a moment



If the unit has already been configured, but if it has not been paired then the message will stay on screen waiting for configuration.

NOTE: Make sure that the U·Meter+, U·Valve, U·Valve+ or U·Count unit is powered on before pairing the U·Vision.

Follow the below instructions to pair the U·Vision:

Starting from the connecting screen press and hold the power button until "setup" is shown on the screen. Release the button.

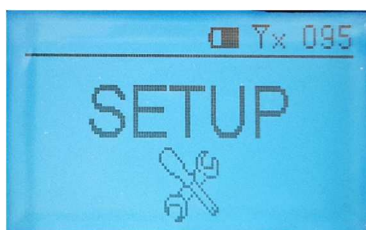

Next the configuration screen is shown automatically. The unit remains waiting for the hose reel number that you want to associate.

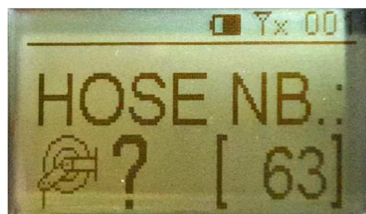

The hose reel number starts to increase automatically. When the desired hose reel number is shown, press and release the power button to set it. In case that the desired hose reel number is missed, press and hold the power button until the counter restarts.

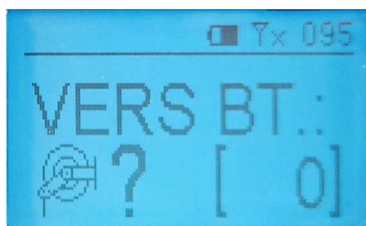



The unit will ask for Bluetooth® enabling. In this case, BT has to be marked as 1.



Once that the hose reel number and BT are set, the screen shows that the configuration is performed and the unit restarts. After restarting the screen shows that the U·Vision is configured and ready to operate.

4.4.8 LOCAL PARAMETERS SETUP ON U·VISION+

This unit can be paired with a U·Meter+, U·Valve, U·Valve+ or U·Count unit.

Pressing any button, the screen shows the start screen during a short time. In the bottom left screen it is shown the U·Vision+ firmware.

Press and hold the  and  buttons until "SETUP" is shown on the screen. Release the buttons.

You will have to use the  and  keys to go to the desired hose reel number that you want to associate.

Once you have reached the number, press .

The unit will ask for Bluetooth® enabling. In this case, BT has to be set as 1.

Once that the hose reel number and BT are set, the screen shows that the configuration is performed and the unit restarts. After restarting the screen shows that the U·Vision+ is configured and ready to operate.

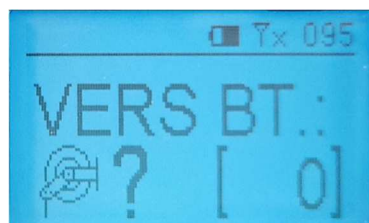
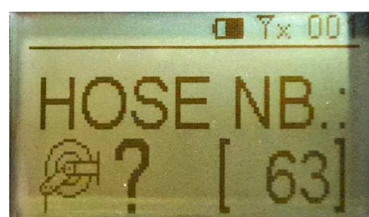
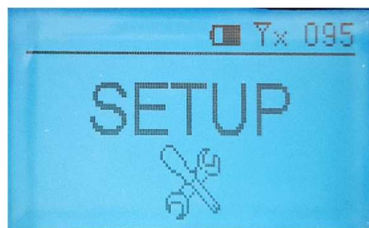

4.4.9 LOCAL PARAMETERS SETUP ON U-TANK

To gain access to the main menu, please insert the bypass key into the unit and switch from

normal position () to bypass position (). The main menu will appear on screen:

- SETUP MENU-

- ▶ - LOCAL SETUP.
- CALIBRATION.
- FACTORY RESET.
- + INFO.

WARNING

When the unit is in bypass mode, both the general air supply and the pump control valves will be activated regardless of the system logic setup.

The arrow at the left side of the screen indicates the currently selected option. Use the "up" and "down" keys on the keypad to select the desired option and press "OK" to confirm

This menu allows for setting the local parameters of the unit (address, End-of-line, number of tanks to be controlled).

The first parameter is the local address. Use the "up" and "down" keys on the keypad to select the desired option and press "OK" to confirm, or press  to go back to the main menu.

The next parameter is the End-of-line. This parameter depends on the unit position inside the NEX-U CANBUS network: if the U-Tank unit is between another two other units elsewhere in the network (in other words, the U-Tank is not at the end of the CANBUS network), set this parameter to "0"; if the U-Tank is at the end of the CANBUS network, set this parameter to "1". Use the "up" and "down" keys on the keypad to select the desired option (the blue E.O.L. status LED will change) and press "OK" to confirm, or press  to go back to the previous parameter.

The last parameter is the number of tanks. The U-Tank unit can control one or two tanks: if only one tank is to be connected to the unit, set this parameter to "1"; if two tanks are to be connected to the unit, set this parameter to "2". Use the "up" and "down" keys on the keypad to select the desired option and press "OK" to confirm, or press  to go back to the previous parameter.

At this point, the display will show "OK! RESTARTING..." and the unit will reboot with the new parameters.

NOTE: The new parameters are stored in the non-volatile memory of the unit only after reaching this last point. Any changes made previously without reaching the "OK!" screen will not be saved.

4.4.10 LOCAL PARAMETERS SETUP ON U·NET

The only setting for the U·Net is the End of Line resistor. By default, it is set to OFF.

If two switches are in the lower position (as shown in the picture) the EoL is OFF. If they are in the upper position, the EoL is ON.



4.4.11 LOCAL PARAMETERS SETUP ON U·CONNECT

To configure the device remotely (Mode 1 or 2) it will be necessary to connect the configuration device (PC or Android Phone) to the Wi-Fi® network that the U·Connect generates.

The SSID of your local network is “U·CONNECT-X” where X will be the local address of the device and it could be changed locally through its configuration. The password to access this network is “123456789”.

Mode 1. Through a PC (Windows) with the configuration app.

Through this application you must only and exclusively enter three parameters:

- SERVER IP: it will tally to the IP of the U·NET of our installation.
- SSID: name of the customer Wi-Fi® network where you want to connect the Wi-Fi® repeater.
- PASSWORD: password of the customer Wi-Fi® network where you want to connect it.

To complete the process, click on “Send” and the configuration process will start automatically.

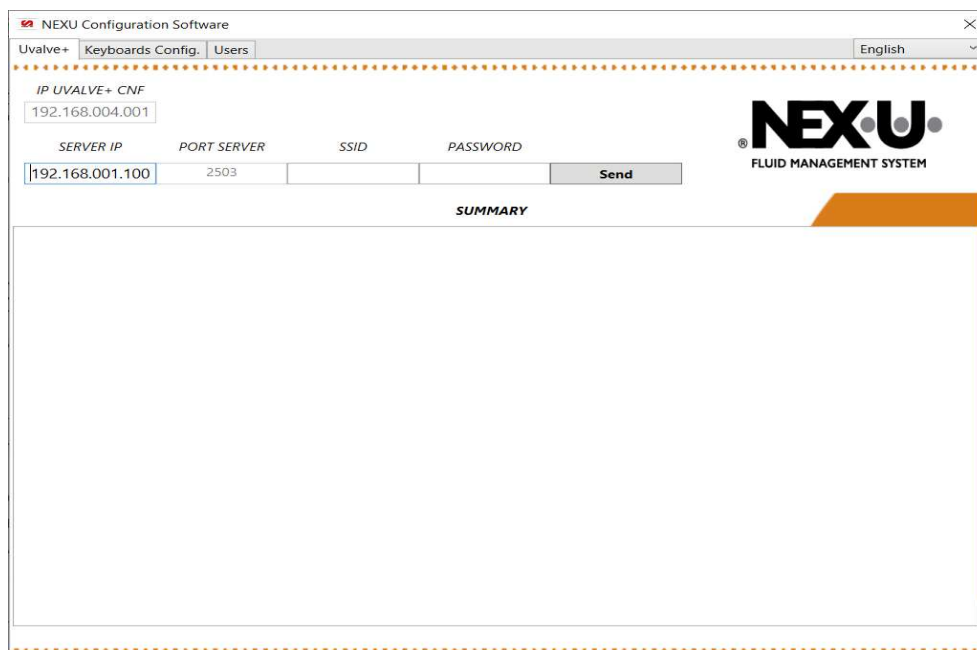

Mode 2. Through a Mobile (Android) with the configuration APP.

For the U-Connect configuration from tan Android phone, there is an App called Usetup that can be supplied by your local NEX-U distributor.

In an Android phone with Wi-Fi® connection, you need to open the available networks and look for U-CONNECT-X (being X the U-Valve number that needs to be configured).

Disable the option Connect automatically and then press Connect. The system will ask for a password. Enter 123456789

Go to the Usetup App and you will get into this screen

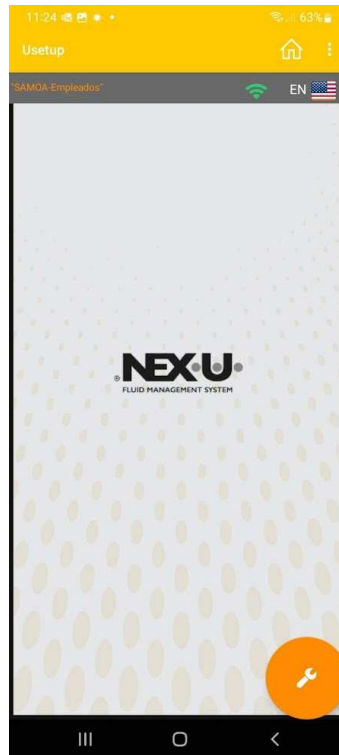

The Wi-Fi® sign has to be in green colour and the connected network and the connected network has to be the U-Connect one (in the picture you see SAMOA-Empleados but you will have to see U-CONNECT-X

Then press this icon  and it will take you to the configuration screen

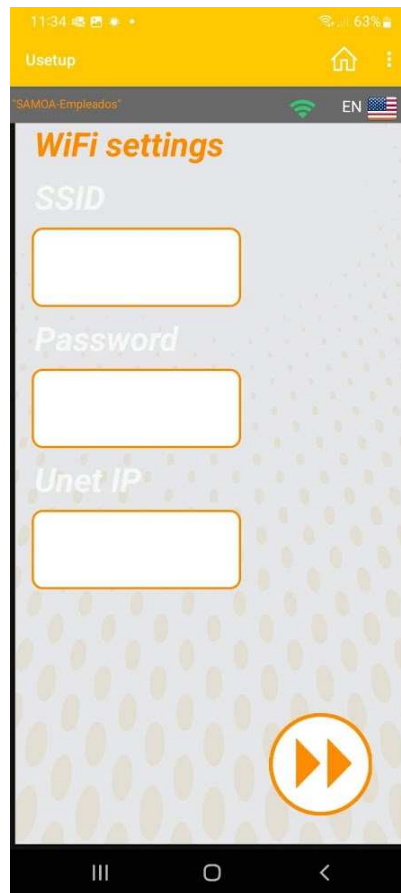

- SSID: Name of the Wi-Fi ® network
- Password: Password of the Wi-Fi ® network
- U·Net IP: U·Net IP (this data has to be provided by the customer)

When everything is set properly, press 

Mode 3. (Recommended one) In the device itself through its configuration section, which will be explained in the next section within the operating mode.

When you turn on the module, it will automatically start the boot process:

Logo is displayed



Firmware version loaded on the device is displayed



Wi-Fi® setup process begins. This process tries to connect to the network that has been configured. (In case of being the first time, there will be no network configured).



If Wi-Fi® setup network has been correct, logo will be displayed. Otherwise, it will appear a logo signaling that there isn't a network available.



To access the SETUP section, you must press the ENTER button continuously, until 'SETUP' appears on the screen.



When you release ENTER button, drop-down configuration will appear with all the available options.

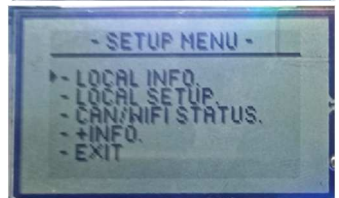

LOCAL INFO: shows all device characteristics.

- DIR LOC: corresponds to the local address of the device. Based on this value, it will create the local network to which you must connect to configure it remotely.
- SSID: is the name of the Wi-Fi® network the device is connected to.
- PWD: is the password that has been entered for the SSID.
- U-NET: is the IP address of the U-NET.
- PORT IN and PORT OUT: these are the input and output ports where the messages are directed.
- IP: is the local IP of the device.



LOCAL SETUP: section that allows the device to be configured locally

First, we can change the local address of the device using UP/DOWN buttons.

To move on to the next item, press the ENTER button. Next you will go through the process of setting up the Wi-Fi® connection. The first step will be to set the IP address of the U-NET.

You can scroll through the different digits using RIGHT/LEFT buttons, and scroll through each digit from 0-9 using UP/DOWN buttons.

Once the correct IP has been set, press ENTER.

At this point, the device will automatically search for available networks and display their SSIDs, so that you can use the UP/DOWN buttons to select the correct SSID and confirm by pressing ENTER again.

Then, you have to enter the corresponding PASSWORD for the SSID selected.

You can scroll through the different digits using RIGHT/LEFT buttons, and scroll through each digit from 0-9 using UP/DOWN buttons.

Once the correct IP has been set, press ENTER.

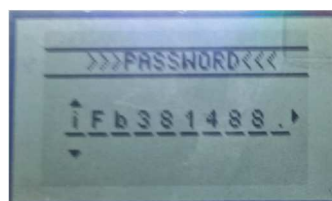
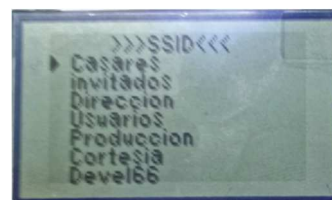
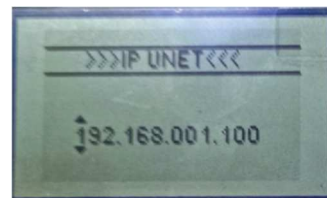
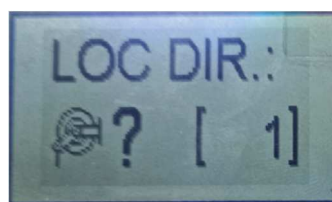

At this time, the device will begin to connect to the selected NETWORK. If the whole process is successful, the assigned IP address will be displayed in the first line, along with the Gateway and subnet mask.

Finally, a setup OK message will be displayed, before the device reboots.

NOTE: In case any error occurs during the Wi-Fi® network connection process, an ERROR message will be displayed. If the ERROR is due to an incorrect SSID or PASSWORD it will be specifically indicated.

4.4.12 LOCAL PARAMETERS SETUP ON U-POWER / U-POWER+

If you open the U-Power / U-Power+, you will find three switches. If you need the EOL to be active, please set all of them (three) in ON position. If you need the EOL to be non-active, they have to be in 1 2 3 positions.

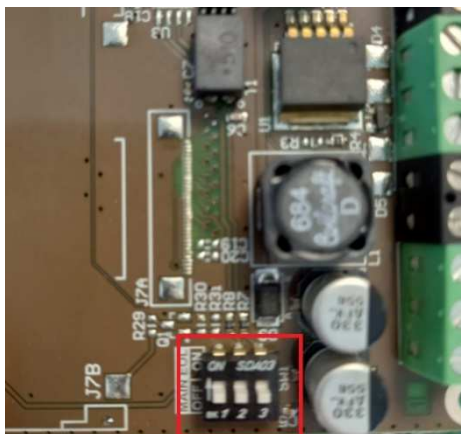

4.4.13 LOCAL PARAMETERS SETUP ON A NETWORK EXTENDER

No need to set any local parameters. Network extender connects to the U·NET automatically.

4.5 DIAGNOSIS OF THE NETWORK STATUS

When we have come to this point it is necessary to assure that the network works correctly. To do this, a diagnosis of the same must be done:

As default,

1. All the green LEDs “CANBUS” on the devices must be:
 - Lighting.
 - Must not be shut off erratically.
2. No power LEDs on the devices must be blinking.
3. No LEDs on the U·Net must be continuously blinking.

This indicates that the CANBUS network works correctly.

To be able to continue with the next step of the start-up procedure of the installation, the global parameters setup, it is essential that the network works correctly.

If this is not the case, cabling must be revised (connection errors, badly tightened connections, etc...). The LEDs can delay their lighting a little after a problem has been corrected, as they are controlled by error counters that are reset only after a specific number of transmissions/receptions done successfully.

5 NEX·U· REQUIREMENTS

To install a U·Net the following requirements are needed

- 110 VDC or 240 VDC (50 Hz / 60 Hz) power mains
- Ethernet connection
- Fixed IP address (supplied by the customer). By setting this IP, the customer will be able to operate on the U·Track.
By default, the U·Track IP is 192.168.1.100:4000
- Mask
- Gateway
- DNS (just in case that an event warning email needs to be sent)
- If U·Valve+ are being installed as many fixed IP addresses as the number of U·Valve+.
- If U·Connect are being installed as many fixed IP addresses as the number of U·Connect.
- UDP 2503 open port for U·Connect

6 SOFTWARE CONFIGURATION

6.1 INSTALLATION PROCESS

There is no installation process. In fact, U·Track is a program already installed in the U·Net and it runs with any current browser (Google Chrome, Mozilla Firefox, Microsoft Edge, Safari...).

The U·Track address is, by default

<http://192.168.1.100:4000>

To set the NEX·U· configuration, it is highly recommendable to do it with a particular PC the IPv4 network address range has to be 192.168.1.101

Once the U·Track configuration is made, the last of the steps will be to change the IPv4 network address according to the customer network.

NOTE: The customer must give us a fixed IPv4 network address to connect the U·Track. This action will allow the customer to access the U·Track from any PC / laptop / mobile phone of the customer facilities (if there are no restrictions from IT department)

6.1.1 HOW TO CHANGE THE IPv4 ADDRESS FOR A LOCAL NETWORK

As we have already said, configuration can be made in a local PC. His PC has to be in the same range as the one of the U·Net. This is the procedure to do it.

The first thing that must be made is connecting the Ethernet wire from the U·Net to the PC. Then a local network will be automatically created (in this example, the name for the network is *Ethernet 2*).

6.1.1.1 WINDOWS 10

Press the Windows Icon and go to the configuration menu

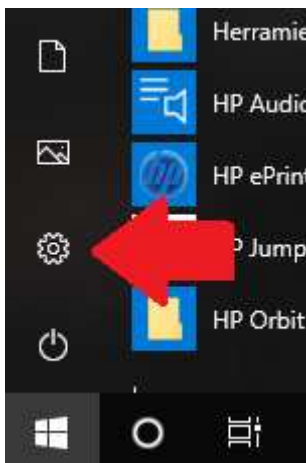

Go to Network and Internet – Status – Network and Sharing Center

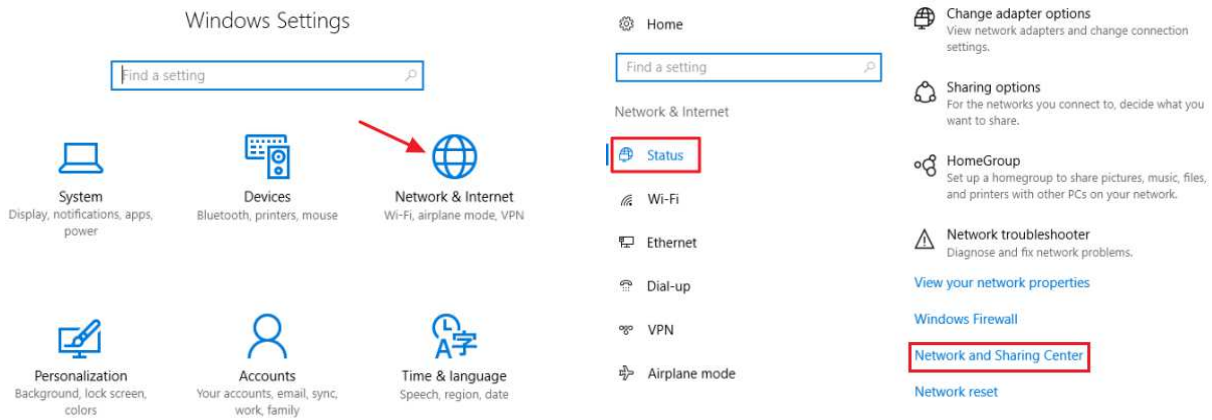

You will find the available networks. In this example, the network is Ethernet 2

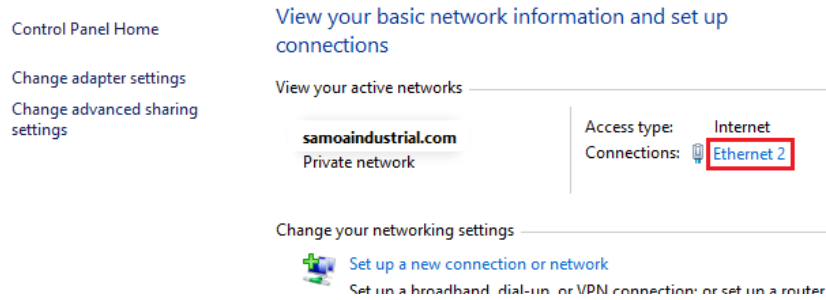

Click on Ethernet 2 and another window will pop up.

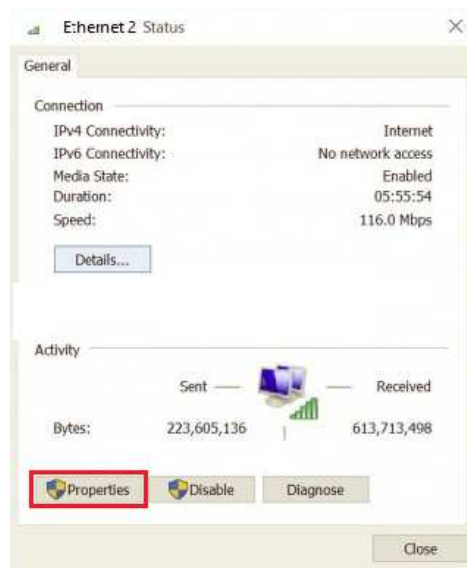

Click on Properties

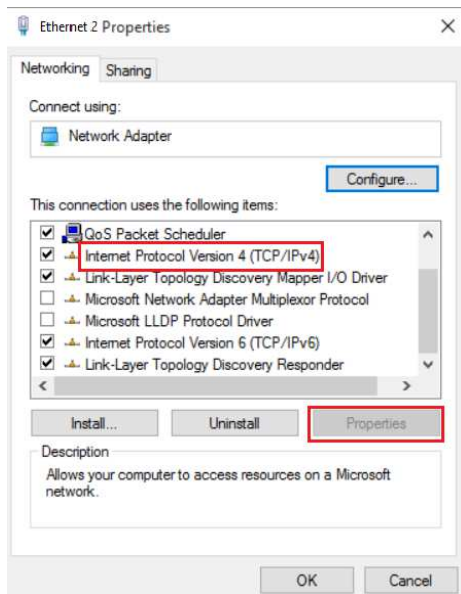

Now Click on Internet Protocol Version 4 (TCP/IPv4)

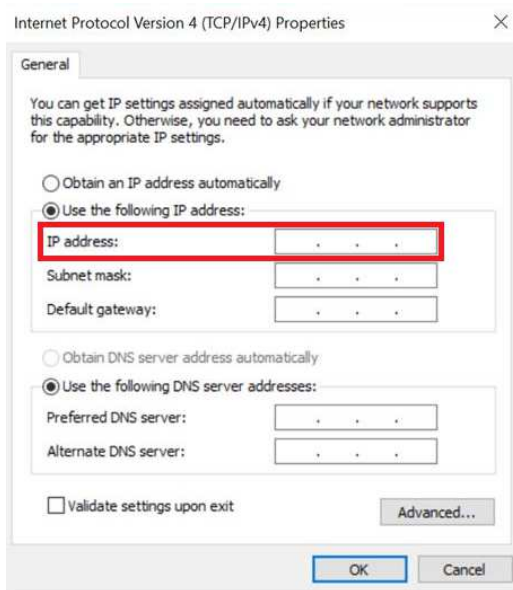

Choose Use the following IP address and set 192.168.1.101 (the Subnet mask will be set automatically to 255.255.255.0 If not, please set it)

Then press OK and once you open the browser again and insert <http://192.168.1.100:4000>, you will be able to access the NEX·U· software

6.1.1.2 WINDOWS 11

Press the Windows Icon and go to the Settings menu

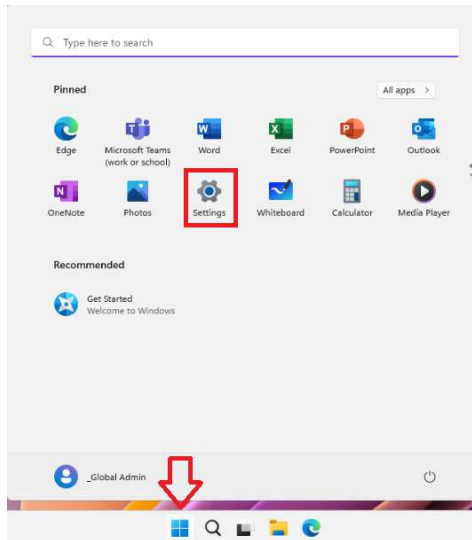

Go to Network and Internet - Ethernet and choose the Network in which the U·NET is installed

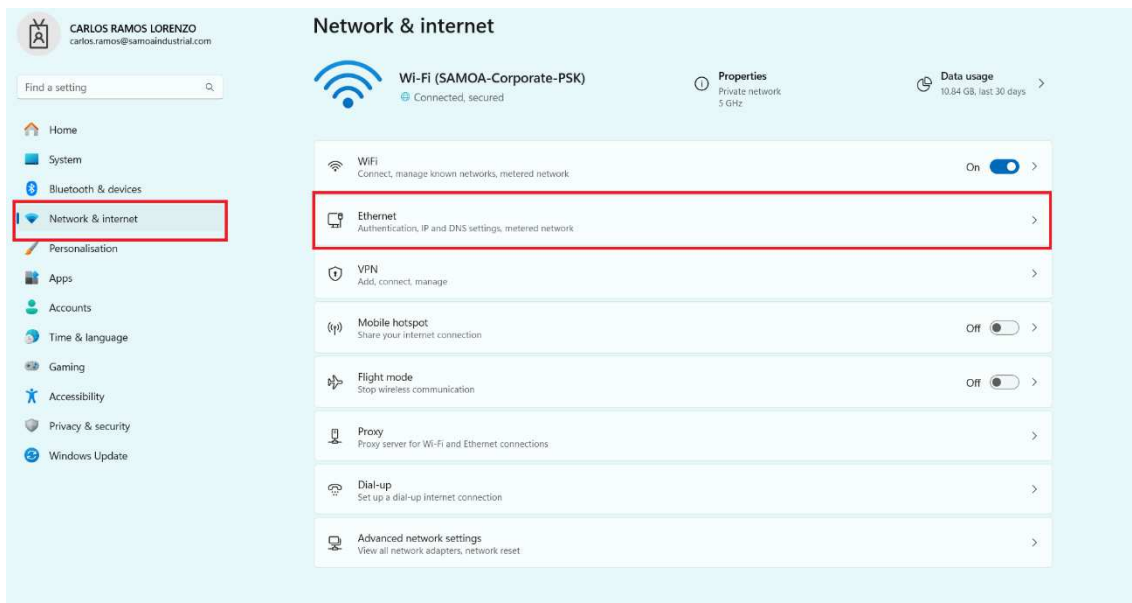

Go to Edit

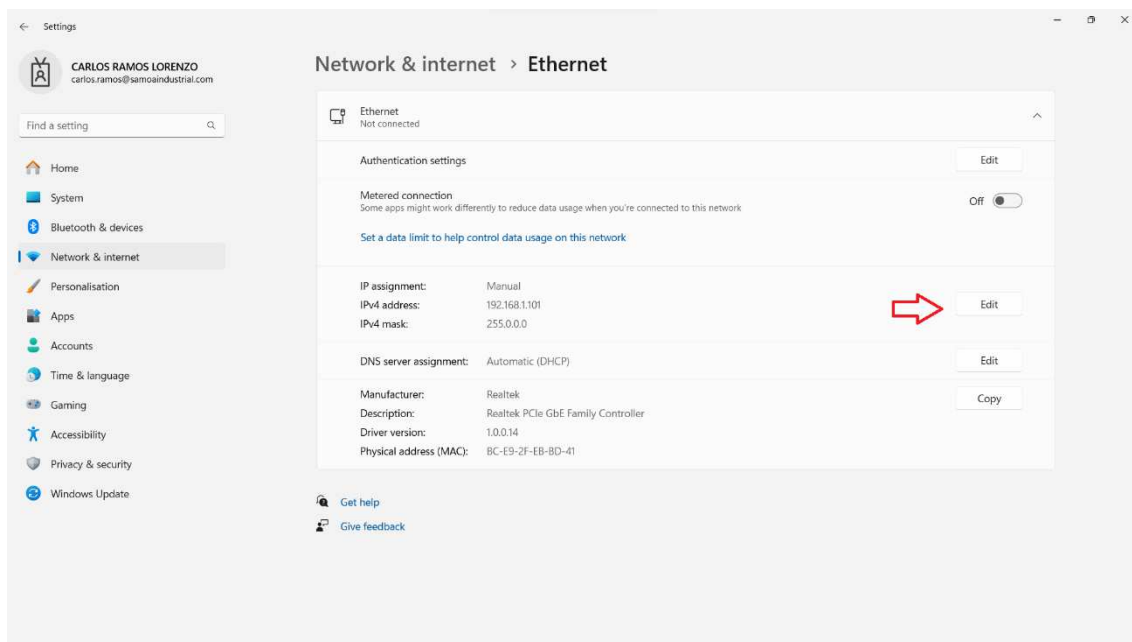

Choose Use the following IP address and set 192.168.1.101 (the Subnet mask will be set automatically to 255.255.255.0 If not, please set it)

The 'Edit IP settings' dialog box is shown. The 'Manual' option is selected in the dropdown menu. The 'IPv4' toggle is turned 'On'. The 'IP address' field contains 192.168.1.101 and the 'Subnet mask' field contains 255.0.0.0. There are 'Save' and 'Cancel' buttons at the bottom.

Then press OK and once you open the browser again and insert <http://192.168.1.100:4000>, you will be able to access the NEX·U· software

6.2 CONFIGURATION PROCESS

This process must be made by a superuser (user with installation rights).

The superuser code is assigned to each distributor individually

You must press the padlock at the upper right part of the screen and insert the superuser credentials



Once you enter, you will see the configuration option in the upper right part



Press that option and you will see a home page with a summary of the installation (if it is not new). It is under the Option “General” You will see the number of products, the number of tanks, the number of devices and the number of groups.

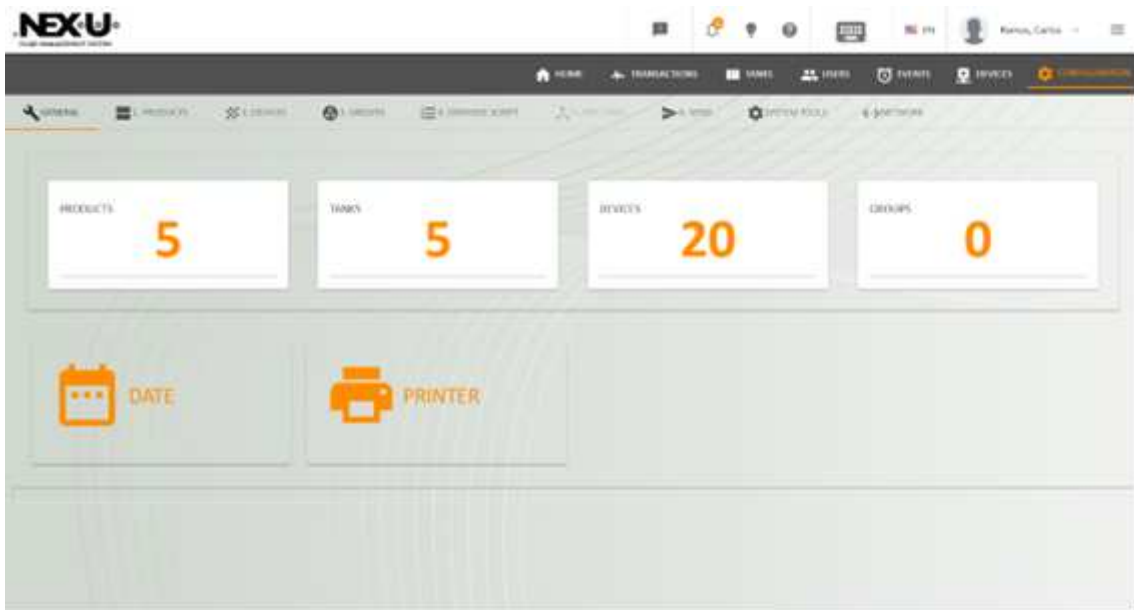

If you click on DATE, you will find menu to change date and time in the system. Please remember to press SAVE once you have set date and time.

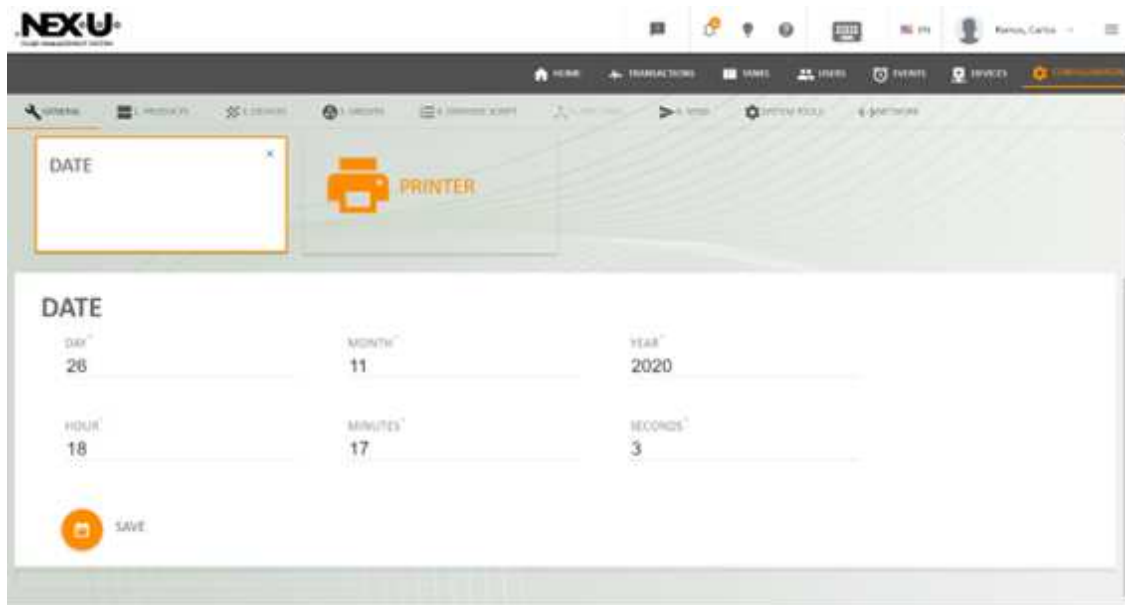

If you click on PRINTER, you will find a menu to set the IP address in which you will be able to connect an external printer in the customer network. You must click ENABLE, set the IP Address and then press SAVE

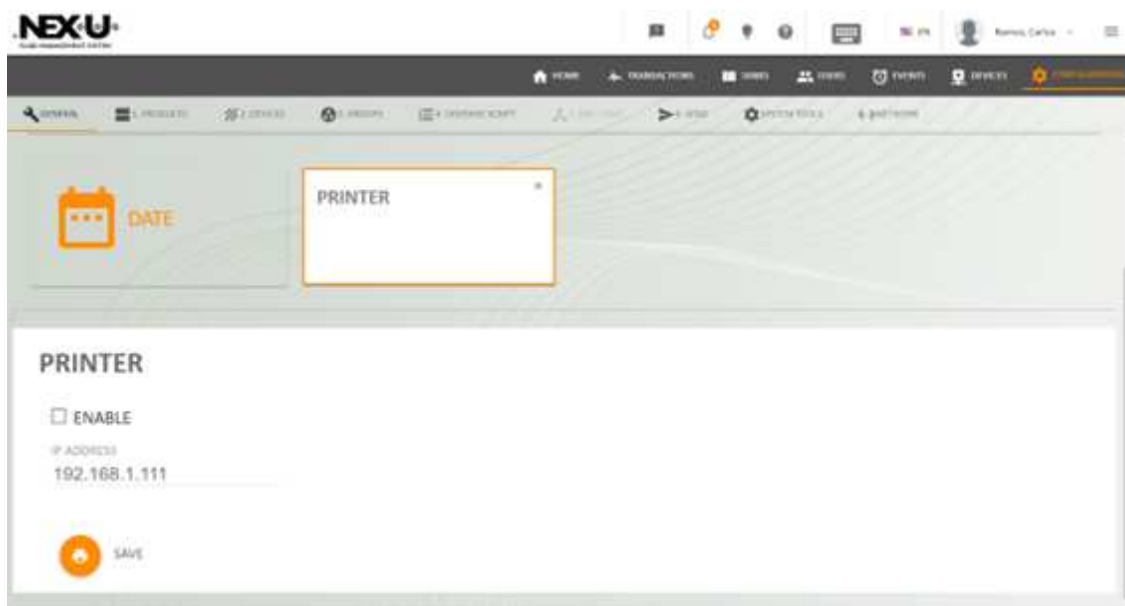

To make the configuration you must follow the steps 1 to 6 shown in the upper part.



6.2.1 PRODUCTS

In this screen you must define the products of the installation.

Press the icon **+** (upper right part) and a popup window appears.

Part Number: This is the part number of the product and must be the same as the one defined in the customer DMS (This parameter is compulsory)

Name: This is the name of the product and has to be the same as the one defined in the customer DMS (This parameter is not compulsory)

Provider: This is the provider of the product (This parameter is compulsory)

Density: This is the density parameter and must be inserted in kg/cm³. This parameter is compulsory if the installation has a U-Tank.

Viscosity: This is the viscosity parameter and must be inserted in cPs

Unit: In this screen you must define the unit you want to work. There are several options: litres, kilograms and gallons.

Once you have finished, press **SAVE** to save the changes.

Product	Name	Provider	Density (kg/m ³)	Viscosity (cPs)	Unit	Active
+	WATER OIL	WATER	1000	100	litres	Active
+	WATER OIL	WATER	1000	100	litres	Active
+	WATER OIL	WATER	1000	100	litres	Active
+	WATER OIL	WATER	1000	100	litres	Active
+	WATER OIL	WATER	1000	100	litres	Active

At the end of the line, you can see a column with “Status” If it is active (green) it means that the product is active and it is part of the installation.

If the customer stops using that product, you have to create a new one and deactivate the previous one (click in the button and it will be red). The product that is not used any more will not be removed from the system.



If you want to change any parameters of any product preciously created, please tick the line and press  (in the right part of the screen) to make the changes.

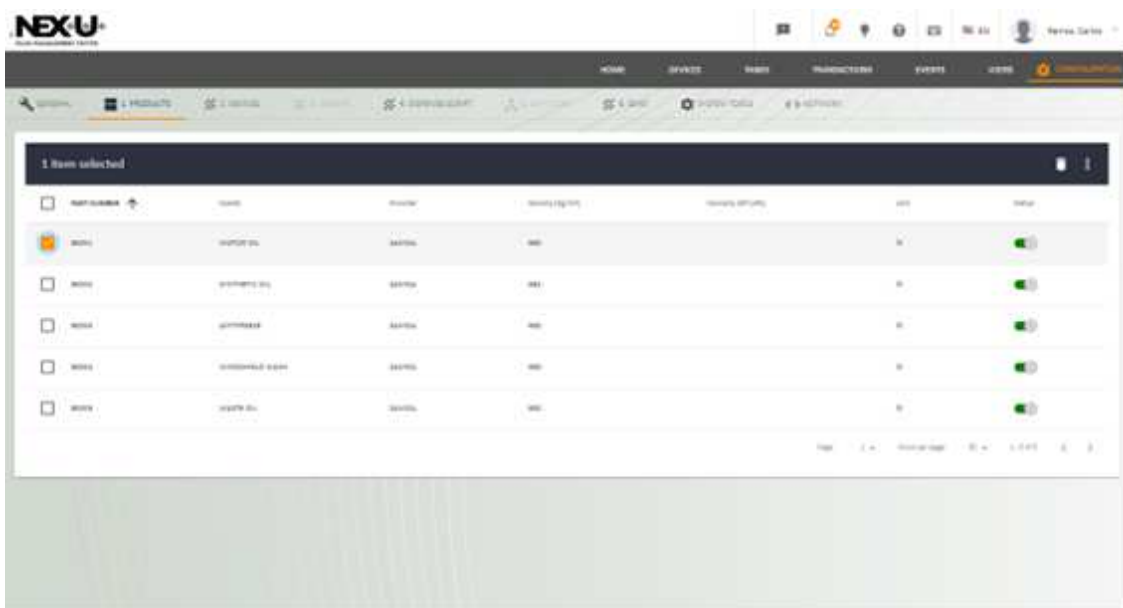

6.2.2 DEVICES

In this screen you will be able to define all the devices of the installation with all the global parameters. The process is very simple. You must choose the desired device in the left part of the window. Press the arrow at the left part and a window will scroll.



Once you scroll it you will see all the elements of the NEX·U· system. If you want to use one, you must click it and then drag & drop it to the central screen.

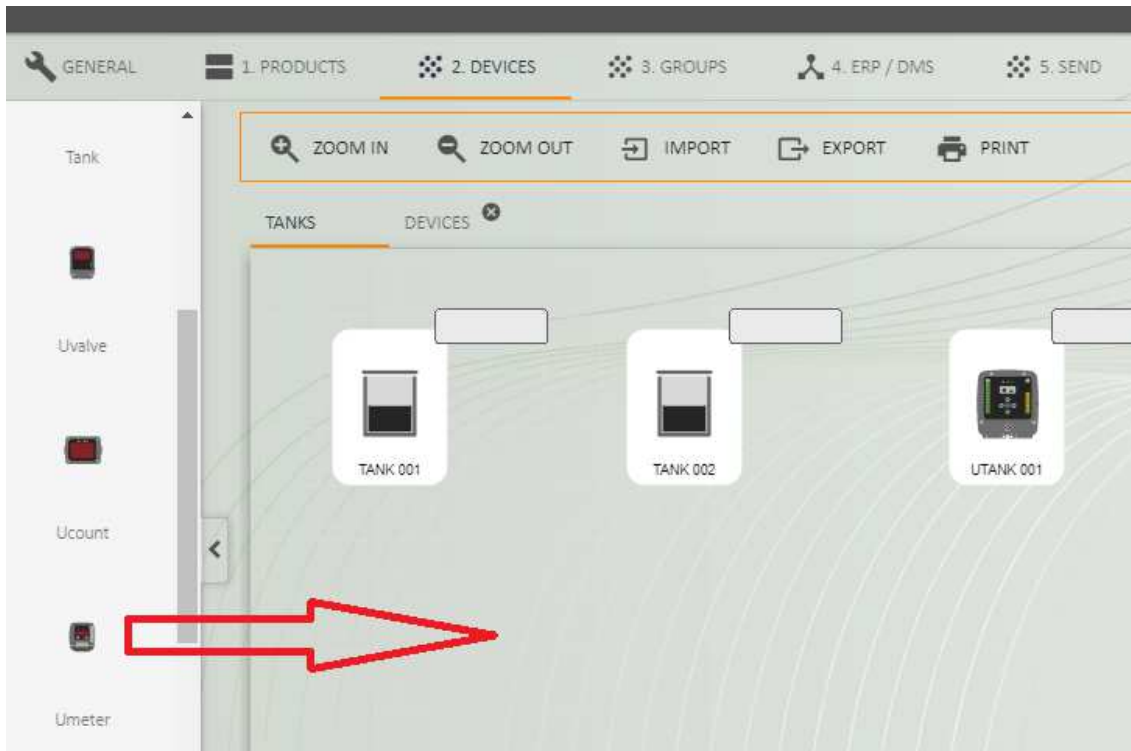

If you want to eliminate the device, you must put the mouse on it. A red cross will appear and if you click it, it will be deleted.



By default, you will see two tabs: Tanks and Devices.

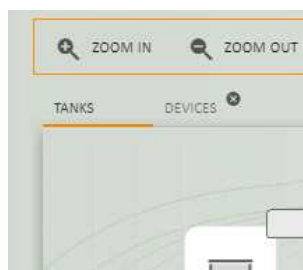

This has been made to make the configuration a little bit easier.

In the first one (Tanks) you can drag the devices related to the Tanks (Tanks, Pumps Room Air Solenoid Valve and U-Tanks). In the second one you can drag the rest of the elements. In any case, if you want to create more tabs, you can double-click in any of the active tabs and a pop-up window will appear.

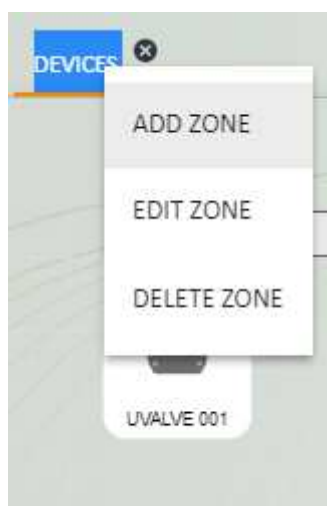

If you press ADD ZONE, a new one will appear. At the same time you can either delete (DELETE ZONE) the zone or edit (EDIT ZONE) the name of the existing zone.

WARNING: If you delete the zone, all the elements included in that zone will disappear.

Once the device has been dragged & dropped, click on it and a left window will appear. You will be able to make the configuration in that window.

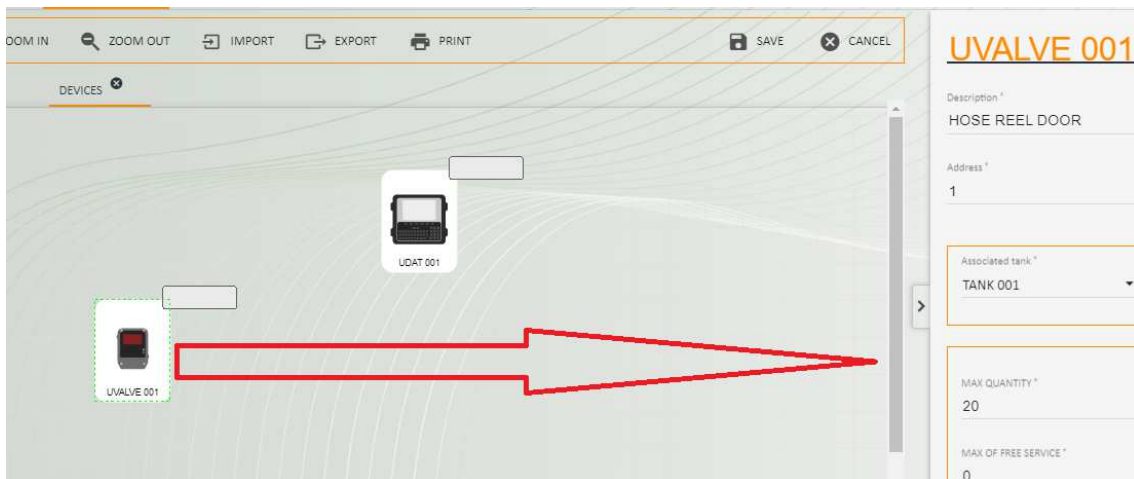



Let's see how to make the configuration of all the elements.

6.2.2.1 U-TANK

If there are U-Tanks in the system, this is the first item you have to create. The parameters are very simple.

Description: You can make a brief description of the U-Tank (i.e.: North Tank Room)

Communication Type: You can set if the U-Tank communication is either wired or wireless. With this U-Track version, only wired is enabled.

Once you have set all the parameters, please press  and then .

6.2.2.2 TANK

First, we have to say that this is not a device of the system. In this menu you must define the parameters of the tank that contains each product already defined in the previous tab.

Description: You can make a brief description of the Tank. Please be aware that we are talking about the product contained in the tank but the tank itself.

Local Address: It gives a number to the tank just for guidance.

Select Product: You must choose the product that is contained in the tank. The products will be the ones already defined in the previous tab.

Choose a colour: You can associate a colour to the product contained in the tank.

U-Tank: It sets if the tank is controlled by a U-Tank or not.

If the tank is not controlled by a U-Tank (Select NO) you must set the current level of the product.

If the tank is controlled by a U-Tank (Select YES) you must set the U-Tank and channel in which the tank probe is connected. A drop-down menu will appear and it will show several options like U-TANK 00X/Y in which X represents the address of U-Tank and Y represents the channel of probe in the U-Tank.

If you need to make a continuous measuring of the liquid level that in the tank, you will have to choose VOLUMETRIC PROBE and you will have to set the pressure probe setting for the probe that is inserted in this tank. As default, the NEX·U· standard probes are set to 400 mBar.

If you only need to make a digital measurement (contact signal) you will have to choose LEVEL SWITCH then you will have to set the warning messages.

Then you must activate the warning messages for both cases.

Activate Level Warning: You must set a warning level in which the system will show a warning in the system with the text you can insert in the Warning level message option.

Activate Stop Level: You must set a Stop level in which the system will show a warning in the system with the text you can insert in the Stop level message option. In this case, once this level is reached, the system will not allow delivering the product. This level must be set so that the pump does not suck air.

Select Tank: You can choose the shape of the tank. If you click, you will see a drop-down menu. In that menu you will find several predefined tanks.

In any case, if the installed tank is not in the list, you can define the tanks with the  button. If you press it a pop-up window will appear

In that window you must fulfil the following data

Model: Insert a name for that model of tank

Supplier: Insert the supplier of the tank (this is a compulsory data)

Select Dimension Type: If this option is chosen, another window appears. This window shows the three possible predefined models: parallelepiped, horizontal cylinder and vertical cylinder. In each option, the main parameters are requested.

Capacity: Once you have inserted the dimension type, the capacity will appear automatically.



Gauging Scales: Once you have inserted the dimension type, the gauging scale will appear automatically.

Select Management Type: You can choose either the tank is used for fresh product or waste product.

Apart from the icon  you will see another two icons

If you press  a pop-up window appears and you will be able to change the parameters of the tank that has already been selected.

If you press  a pop-up window appears and the system asks for a *.cuv table where the height and volume relationship is defined. This file (txt file) must be created and exported by the U·Track.



Once you have set all the parameters, please press  and then .

6.2.2.3 U·DAT

Description: You can make a brief description of the keypad (i.e.: Quick Service Keypad)

Local Address: The system sets a local address automatically. You can rename it just in case you need it.

Communication Type: Not applicable.

Once you have set all the parameters, please press  and then .

6.2.2.4 U·VALVE / U·VALVE+

Description: You can make a short description of the U·Valve (i.e.: Quick Service U·Valve)

Address: The system sets a local address automatically. You can rename it just in case you need it.

Associated Tank: You must associate the tank that is physically connected to the device. When you choose the tank, you will see the name of the tank and the name of the product inside the tank; i.e. GREEN TANK (15W40)

Max Quantity: Regulates the maximum quantity that is possible to dispense in one transaction with previous preset value, including the first transaction and the topping (additional filling up quantities).

Display Quantity: Activates or deactivates the showing of the transaction on the display integrated on the device. If this option is not chosen, moving arrows are showed on the display during the transaction.

Pulse meter Value: This parameter corresponds to the nominal value of the Pulse meter. The U·Valve incorporates a pulse generator of 328 Pulses per minute (PPL).

SV Aperture Delay: Regulates the time the solenoid valve takes to open after the transaction confirmation.

Suspension Time: Regulates the pause time without receiving pulses from the pulse generator. If the transaction is interrupted for a time longer than this value, the transaction is counted as finished and the solenoid valve closes automatically.

Top Up Time: Regulates the waiting time after the initial transaction is completed, making it possible to do an additional topping in the same transaction although the preset quantity is achieved. After this stated time, it is not possible to dispense an additional quantity to the transaction and it is considered as completed.

For example, we have ordered 4 litres and after that these 4 litres have been dispensed, this is the time available for making an additional topping to the original transaction (for example another 0.2 litres, because even if we initially thought that the crank case had 4 litres, when the 4 litres are dispensed and the dip stick is checked we see that we need to fill in a little more). During this time, the display integrated in the device will show “top” giving the possibility to extend the transaction.

Remote Display 1: Selection of a remote display (U·View) to show the volume that is being dispensed.

Remote Display 2: Selection of a second remote display (U·View) to show the volume that is being dispensed.

K Factor: You can change the calibration factor if it already known. In any case, it is automatically changed when the calibration procedure is made in the U·Dat.

Manual Calibration: You can make a manual calibration with this option. There are two fields that have to be fulfilled.



Requested Qty: This is the quantity you order when you want to make the unit calibration

Dispensed Qty: This is the real quantity that has been dispensed when the requested quantity was ordered

The K Factor is automatically calculated based on the two previous figures.

If you press  the unit will get the new parameters and it will be calibrated.

Product Label for U·Vision: If a U·Vision is linked to this U·Valve, you can set a small name that will appear on the upper right part of the U·Vision screen.

Once you have set all the parameters, please press  and then 

6.2.2.5 U·METER / U·METER+

Description: You can make a brief description of the U·Meter (i.e.: Quick Service U·Meter)

Address: The system sets a local address automatically. You can rename it just in case you need it.

Associated Tank: You must associate the tank that is physically connected to the device. When you choose the tank, you will see the name of the tank and the name of the product inside the tank; i.e. GREEN TANK (15W40)

Display Quantity: Activates or deactivates the showing of the transaction on the display integrated on the device. If this option is not chosen, moving arrows are showed on the display during the transaction.

Pulse meter Value: This parameter corresponds to the nominal value of the Pulse meter.

SV Aperture Delay: Regulates the time the solenoid valve takes to open after the transaction confirmation.

Suspension Time: Regulates the pause time without receiving pulses from the pulse generator. If the transaction is interrupted for a time longer than this value, the transaction is counted as finished and the solenoid valve closes automatically.

Top Up Time: Regulates the waiting time after the initial transaction is completed, making it possible to do an additional topping in the same transaction although the preset quantity is achieved. After this stated time, it is not possible to dispense an additional quantity to the transaction and it is considered as completed.

For example, we have ordered 4 litres and after that these 4 litres have been dispensed, this is the time available for making an additional topping to the original transaction (for example another

0.2 litres, because even if we initially thought that the crank case had 4 litres, when the 4 litres are dispensed and the dip stick is checked we see that we need to fill in a little more). During this time, the display integrated in the device will show “top”, giving the possibility to extend the transaction.

Remote Display 1: Selection of a remote display (U·View) to show the volume that is being dispensed.

Remote Display 2: Selection of a second remote display (U·View) to show the volume that is being dispensed.

K Factor: You can change the calibration factor if it already known. In any case, it is automatically changed when the calibration procedure is made in the U·Dat.

Manual Calibration: You can make a manual calibration with this option. There are two fields that must be fulfilled.

Requested Qty: This is the quantity you order when you want to make the unit calibration



Dispensed Qty: This is the real quantity that has been dispensed when the requested quantity was ordered

The K Factor is automatically calculated based on the two previous figures.

If you press  the unit will get the new parameters and it will be calibrated.

Max Quantity: Regulates the maximum quantity that is possible to dispense in one transaction with previous preset value, including the first transaction and the topping (additional filling up quantities).

Product Label for U·Vision: If a U·Vision is linked to this U·Valve, you can set a small name that will appear on the upper right part of the U·Vision screen.

Once you have set all the parameters, please press  and then 

6.2.2.6 U·COUNT

Description: You can make a short description of the U·Count (i.e.: Quick Service U·Count)

Address: The system sets a local address automatically. You can rename it just in case you need it.

Associated Tank: You must associate the tank that is physically connected to the device.

Display Quantity: Activates or deactivates the showing of the transaction on the display integrated on the device. If this option is not chosen, moving arrows are showed on the display during the transaction.

Pulsemeter Value: This parameter corresponds to the nominal value of the Pulse meter that is connected to the U·Count.

SV Aperture Delay: Regulates the time the solenoid valve takes to open after the transaction confirmation.

Suspension Time: Regulates the pause time without receiving pulses from the pulse generator. If the transaction is interrupted for a time longer than this value, the transaction is counted as finished and the solenoid valve closes automatically.

Top Up Time: Regulates the waiting time after the initial transaction is completed, making it possible to do an additional topping in the same transaction although the preset quantity is achieved. After this stated time, it is not possible to dispense an additional quantity to the transaction and it is considered as completed.

For example, we have ordered 4 litres and after that these 4 litres have been dispensed, this is the time available for making an additional topping to the original transaction (for example another 0.2 litres, because even if we initially thought that the crank case had 4 litres, when the 4 litres are dispensed and the dip stick is checked we see that we need to fill in a little more). During this time, the display integrated in the device will show “top” giving the possibility to extend the transaction.

Remote Display 1: Selection of a remote display (U·View) to show the volume that is being dispensed.

Remote Display 2: Selection of a second remote display (U·View) to show the volume that is being dispensed.

K Factor: You can change the calibration factor if it already known. In any case, it is automatically changed when the calibration procedure is made in the U·Dat.

Manual Calibration: You can make a manual calibration with this option. There are two fields that must be fulfilled.

Requested Qty: This is the quantity you order when you want to make the unit calibration



Dispensed Qty: This is the real quantity that has been dispensed when the requested quantity was ordered

The K Factor is automatically calculated based on the two previous figures.

If you press  the unit will get the new parameters and it will be calibrated.

Max Quantity: Regulates the maximum quantity that is possible to dispense in one transaction with previous preset value, including the first transaction and the topping (additional filling up quantities).

Product Label for U·Vision: If a U·Vision is linked to this U·Valve, you can set a small name that will appear on the upper right part of the U·Vision screen.

Once you have set all the parameters, please press  and then 

6.2.2.7 U·LINK

Description: You can make a brief description of the U·Link (i.e.: Quick Service Trolley)

Address: The system sets a local address automatically. You can rename it just in case you need it.

Associated Tank: You must associate the tank that is linked to the device. When you choose the tank, you will see the name of the tank and the name of the product inside the tank; i.e. SERVICE DRUM (15W40)

Operation Mode: There are three operation modes for the U·Link that must be set in this menu

Standard mode: In this case, the user must enter technician PIN number manually or with an RFID tag, then job order and quantity

Preset: In this case, the job order is pre-recorded in the Utrack (go to Transactions / Presets menu) and the user must scroll and choose the job order in the U·Link. Then quantity confirmation in the U·Link is required.



Remote mode: In this case, job order is launched in the virtual keypad then quantity confirmation in the U·Link is required.

Max Quantity: It regulates the maximum quantity that is possible to dispense in one transaction with previous preset value, including the first transaction.

Suspension Time: It regulates the pause time without receiving pulses from the pulse generator. If the transaction is interrupted for a time longer than this value, the transaction is considered as finished and the solenoid valve closes automatically.

K Factor: You can change the calibration factor if it already known. In any case, it is automatically changed when the calibration procedure is made in the U·Link.

Product Label: You can set a small name that will appear on the upper right part of the screen.

Once you have set all the parameters, please press  and then 

6.2.2.8 U·VIEW

Description: You can make a brief description of the U·Vision (i.e.: Quick Service U·View)

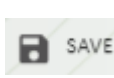
Once you have set all the parameters, please press  and then 

6.2.2.9 U·VISION

Description: You can make a brief description of the U·Vision (i.e.: Quick Service U·Vision)

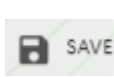
Once you have set all the parameters, please press  and then 

6.2.2.10 U·VISION+

Description: You can make a brief description of the U·Vision (i.e.: Quick Service U·Vision)

Address: Address of the device to which the U·Vision is connected to (U·Valve or U·Meter+).

Mode: Normal, Preset and Workorder Validation. (NOTE: The Preset mode can only be made when the PRESET mode is chosen in the GENERAL Screen)

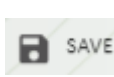
Once you have set all the parameters, please press  and then 

6.2.2.11 AIR SV

Description: You can make a brief description of the Solenoid Valve (i.e.: North Tank Room Solenoid Valve)

Selected U·Tank: You must set the U·Tank number which the Solenoid Valve is connected to.

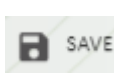
Once you have set all the parameters, please press  and then 

6.2.3 GROUPS

In this menu you will be able to make groups with certain privileges to restrain the ability of dispensing products or using hose reels or keypads.

Press + and a Pop-up window will appear

GROUP
✕

NAME *
This field is required

USERS ▼

PRODUCTS ▼

DISPENSE POINT ▼

U·DAT ▼

Active

SAVE
CANCEL

Name: You can make a brief description of the group (i.e.: Mercedes-Benz Users)

Users: You can set the customers in this group

Products: You can set the products that the customers can dispense

Dispense Point: You can set the dispense points in which the customers can dispense

U·Dat: You can set U·Dat in which the customers can dispense

Active: You can enable or disable this group by ticking/unticking this option.

6.2.4 DISPENSE SCRIPT

With this option you will set the way you want to insert the job orders as well as more data.

On the left part of the screen (Dispense Script) you can see which are the required data when you insert a job order. If you want the data to be required, you must move the button to the right so that the colour gets green.

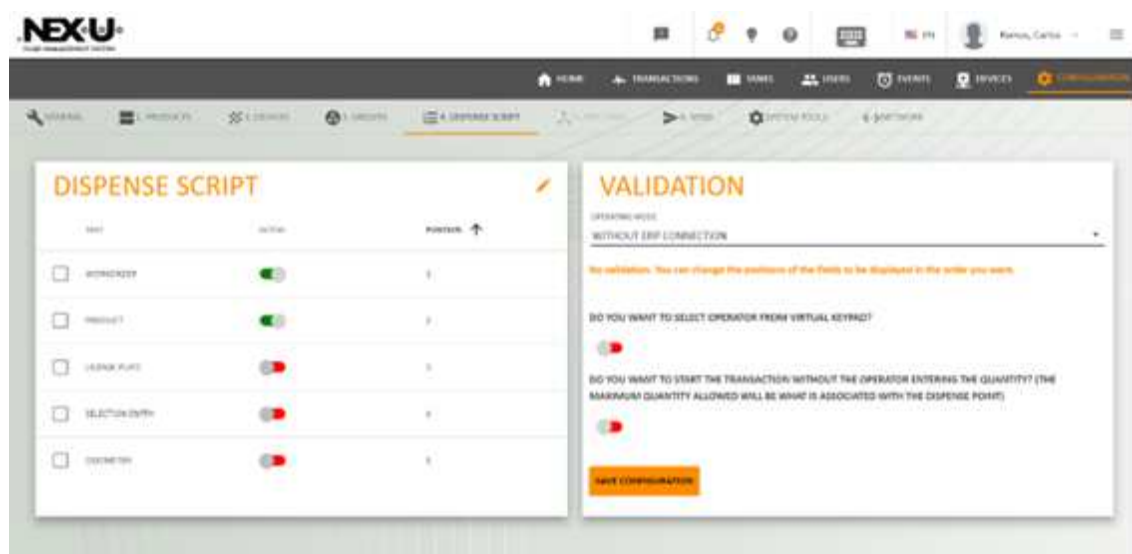

2024_07_24-10:02

If you click on the tick of any text and then , a new screen will appear and you will be able to choose the key position in which the text appears when the job order is inserted.

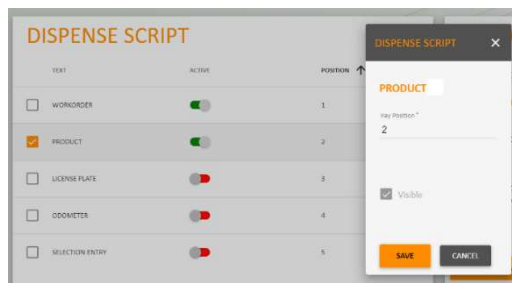

On the right part of the screen (Validation) you can set how you want to work. There are several options.

- Without ERP connection: No validation from the Data Management System (DMS). You can change the positions of the fields to be displayed in the order you want.

You can select if an operator can be selected from virtual keypad.

As well, you can choose to deliver oil without inserting a quantity

- Workorder Validation: Before the transaction is allowed, the work order is sent to the DMS for validating. If the DMS confirms that the work order exists, the user may continue with the process, otherwise access is denied.

With this option you can choose to deliver oil without inserting a quantity

As well, you can set an Override code just in case you need to make a dispense without entering a job order.

- Preset: (Validated Preset Transactions). The user types the work order and selects the product. The system searches in the local database and check if it exists. If so, the required quantity is returned. The same workorder with different products cannot be used, in that case use the PRELOAD mode
- ERP Preset: The user types the work order and selects the product. The system asks DMS if the order is opened and associated with that product. If it is, the DMS set the required quantity.
- Preset Direct: The user concatenates work order and dispense point in the work order field (XXXXX.YYY). The system sends the information to the DMS and the DMS, if the information is validated, returns the maximum quantity.
- Product Preload: The user types the work order and selects the product. The system searches in the local database and check if it exists. If so, the required quantity is returned.

There is an option in which the user can modify the preset quantity.

- Menu Pricing: The DMS sends work orders to the local database via web services. The system validates the work order and the DMS asks for the dispensed quantity after the transaction is completed.
- API: The DMS sends work orders to the local database via web services with a proprietary API. The system validates the work order and the DMS asks for the dispensed quantity after the transaction is completed.

You can set an Override code just in case you need to make a dispense without entering a job order.

- CDK Global: Before the transaction is allowed, the work order is sent to the CDK GLOBAL for validating. If the DMS confirms that the work order exists, the user may continue with the process, otherwise access is denied.

With this option you can choose to deliver oil without inserting a quantity

As well, you can set an Override code just in case you need to make a dispense without entering a job order.

- All in One: Before the transaction is allowed, the work order is sent to the CDK GLOBAL for validating. If the DMS confirms that the work order exists, the user may continue with the process, otherwise access is denied.

As well, you can set an Override code just in case you need to make a dispense without entering a job order.

- Asanet: Asanet sends the list of work orders and positions, with associated product. See the transactions in the preset list. Format WORKORDER.POSITION.

6.2.5 ERP / DMS

Please contact your distributor to enable this option.

6.2.6 SEND

The last step of the configuration is sending it to the devices on-site.

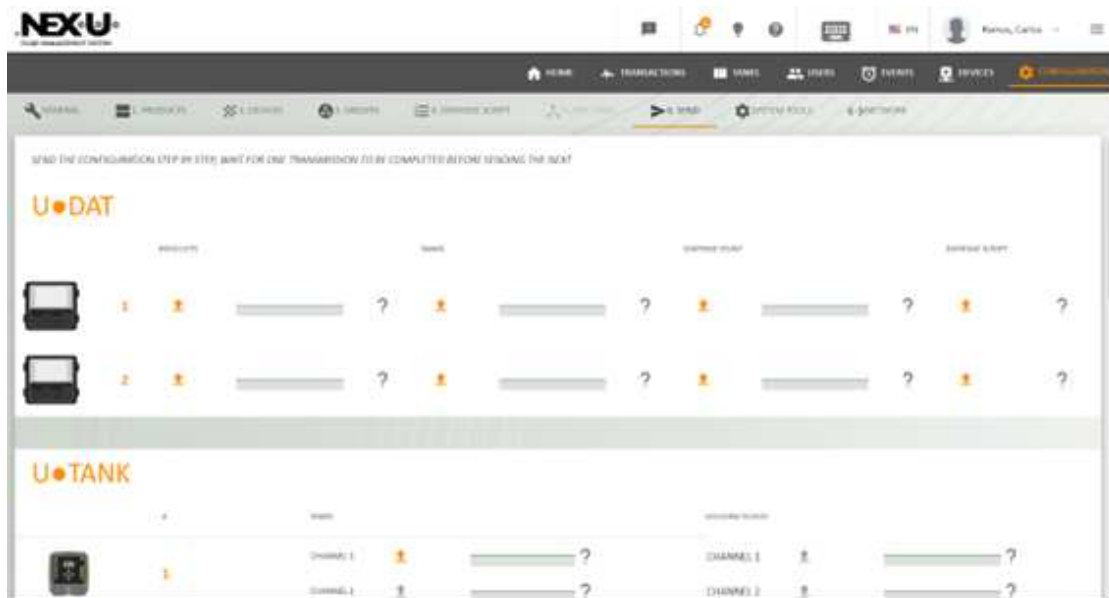

You can do it by clicking  in every block.

U•DAT



Warning: Do not click on any  while the configuration is sent. Please wait until the block sending confirmation green tick appears.

6.2.7 SYSTEM TOOLS

In this menu you have four options.

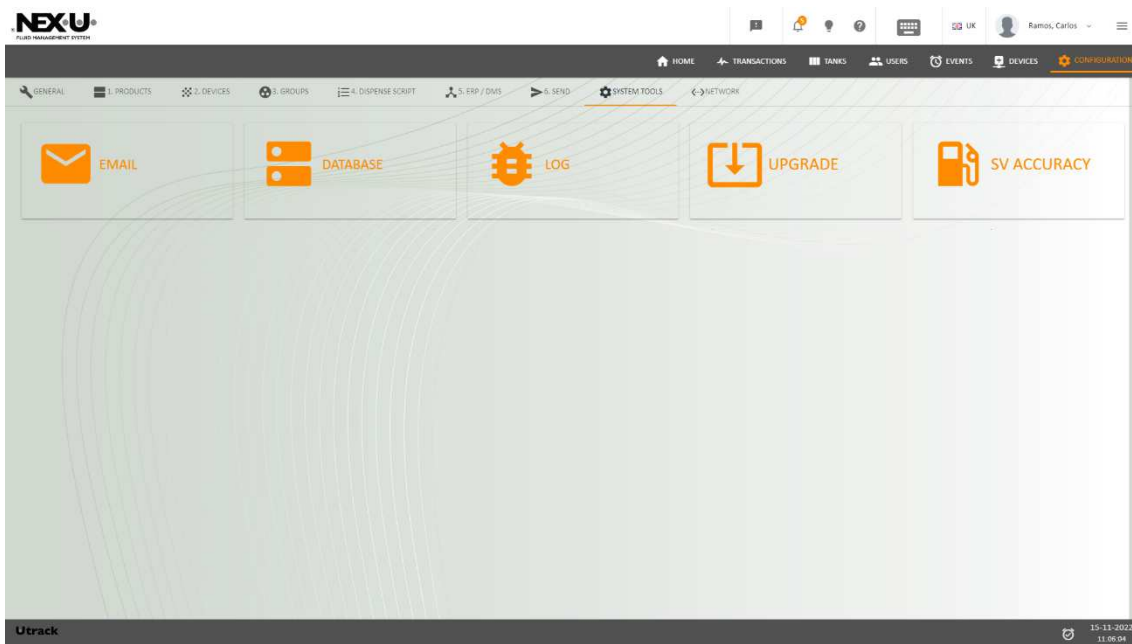

EMAIL: With this menu you can check if the mail delivery option is properly set. You have to say if this email is either Cloud-based or SMTP. In this case, apart from a valid email, you will have to insert all the SMTP parameters. If the email setting is properly made, you will receive an email from nexulinter@gmail.com



DATABASE: You can find two different characteristics

Query: You can set several options

- Customer ID: You can set the text that will appear in the upper left part of the home screen.
- Show / Hide Disabled users: If any users / administrators are disabled, this option enables hiding of those users / administrators in the list.
- VK User (Session time): Time in which the virtual keypad is closed once the transaction is completed.
- Close VK sessions: It closes all the virtual keypads which are open at that moment.
- Decimal separator: It sets the decimal separator. Either “,” or “.”
- Delete TR in progress: It deletes the transactions in progress which are stuck in the process (due to a power cut, for instance)
- Delete Transactions: It deletes the transactions already made. This is useful when you want to delete the test transactions in the commissioning process.
- Delete Events: It deletes the events already made. This is useful when you want to delete the test transactions in the commissioning process.
- Delete Comdevice: It restart the devices communication parameters.
- API Token: Required data when Taylor-made configuration is made. No data must be inserted if you are creating a standard configuration.

To get into that option, you must click on the left orange icon (i. e. )

Backup: You can set two options:

- Create: If you press the icon , a configuration and transactions backup is made in the USB dongle inserted in the rear part of the U·Net (NOTE: The U·Net automatically back up the configuration and transactions data weekly)
- Restore: If you press the icon , a configuration and transactions backup is uploaded from the USB dongle inserted in the rear part to the U·Net. WARNING: All the data in the U·Net will be deleted once you make this action.
- Factory Reset: It deletes transactions, events and users of the U·Track database.

LOG: It shows the configuration changes traceability.

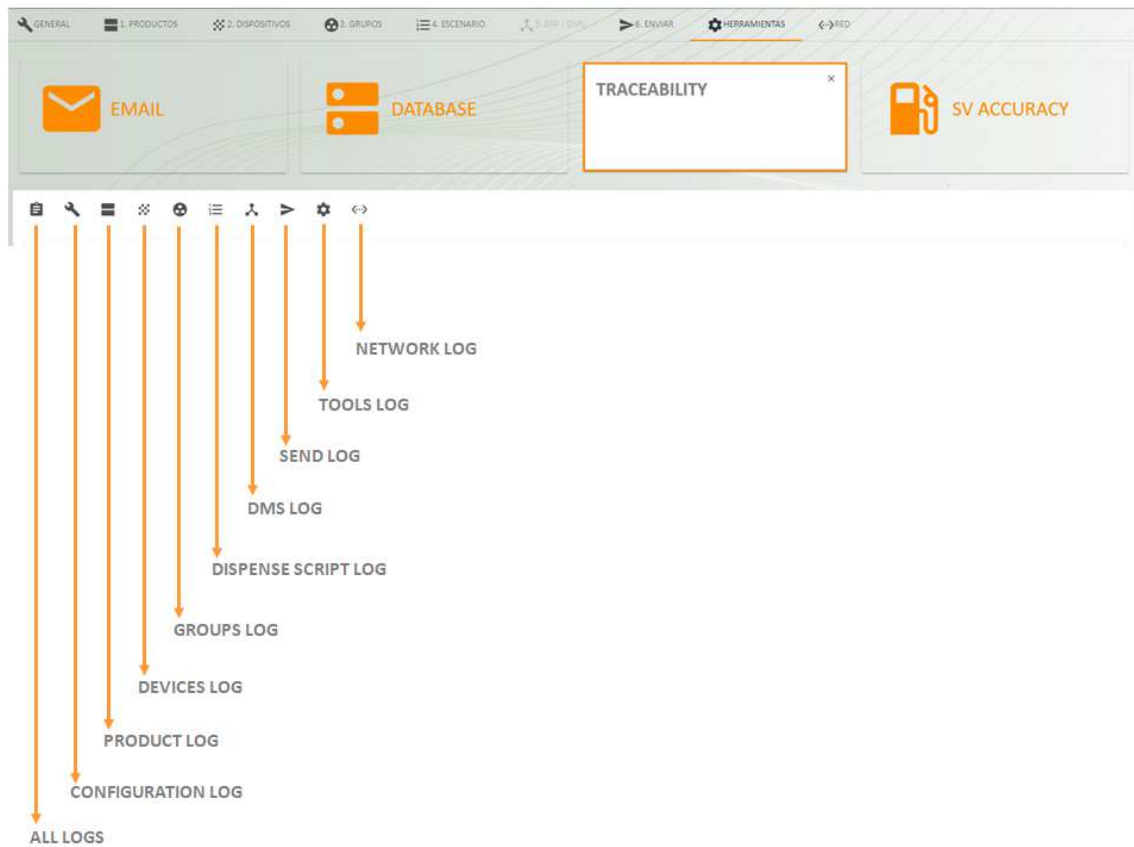

UPGRADE: Not available in this version.

SV ACCURACY: With this option you can set a more precise calibration.

The first step is to select the dispense point. After pressing PRESS TO GET PARAMETERS button to get the dispense point settings.

The software will show PPL and K FACTOR and ask for the dispensed quantity over the required quantity.

With that information the system calculates anticipation parameter and by pressing the **SEND** button it is set in the configured unit.

With that information the system calculates anticipation parameter and by pressing the SEND button it is set in the configured unit.

ANTICIPATION

DISPENSE POINT

 UVALVE 001 ▾

 PRESS TO GET PARAMETERS

PPL: 328 K FACTOR: 1000

TYPE THE EXCESS QUANTITY

 SEND

6.2.8 NETWORK

In this menu you can set all the data for linking NEX·U· to the customer's network.

If you want to use the U·Net with a DHCP configuration, tick the option. If not, which is the recommended option, then the requested data are:

IP Address

Mask

Gateway

DNS (just in case the user wants to send emails when an alarm is reached)

IMPORTANT: Once you have set the previous parameters of the network, the 192.168.1.100:4000 address link is broken. You would need to get into the customer network and access to U·Track by inserting the new IP address in the browser.

7 MANAGER

Once you open the IP address designed by the customer, you will get the main screen.



You must go to  and then insert user and password.

At the left lower part of the screen, you will see the number of transactions in progress and details of the transactions. (In this case there is one transaction in progress, the job order is 1, the delivered liquid is 0W30 and it has been made by Samoa, Admin).

The upper bar shows six different submenus



We will go through all of them to show all the possibilities.

7.1 HOME

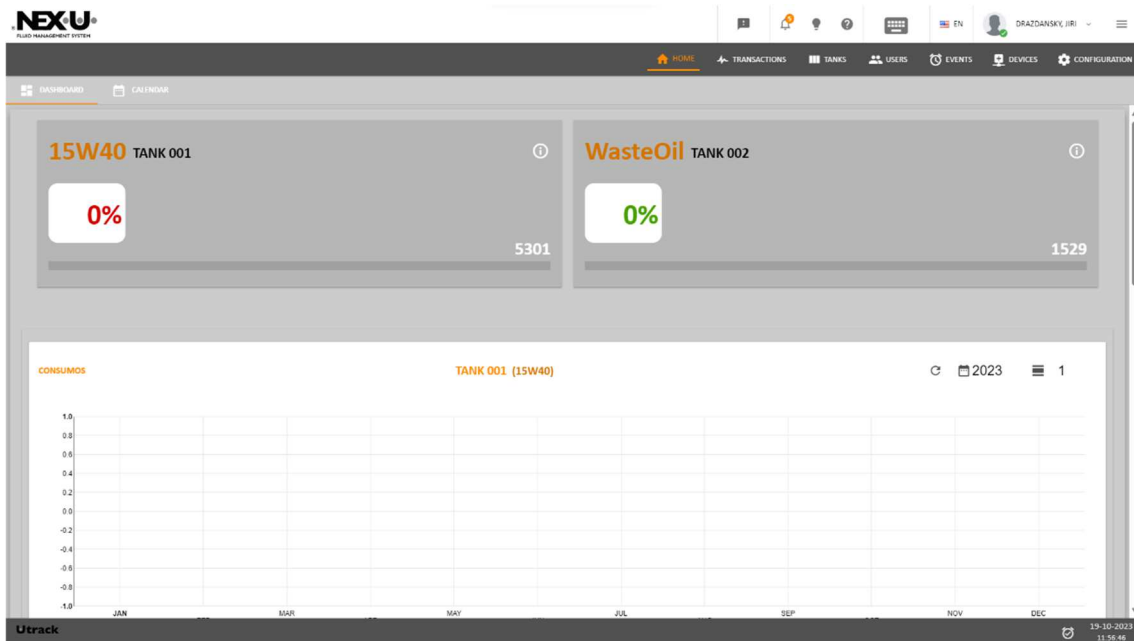

In the upper part you will see a rolling screen in which the situation of the tanks is available.

In that upper right part of that sub-window, you can see . If you press it, that sub-windows will turn and it will show more data about that tank.

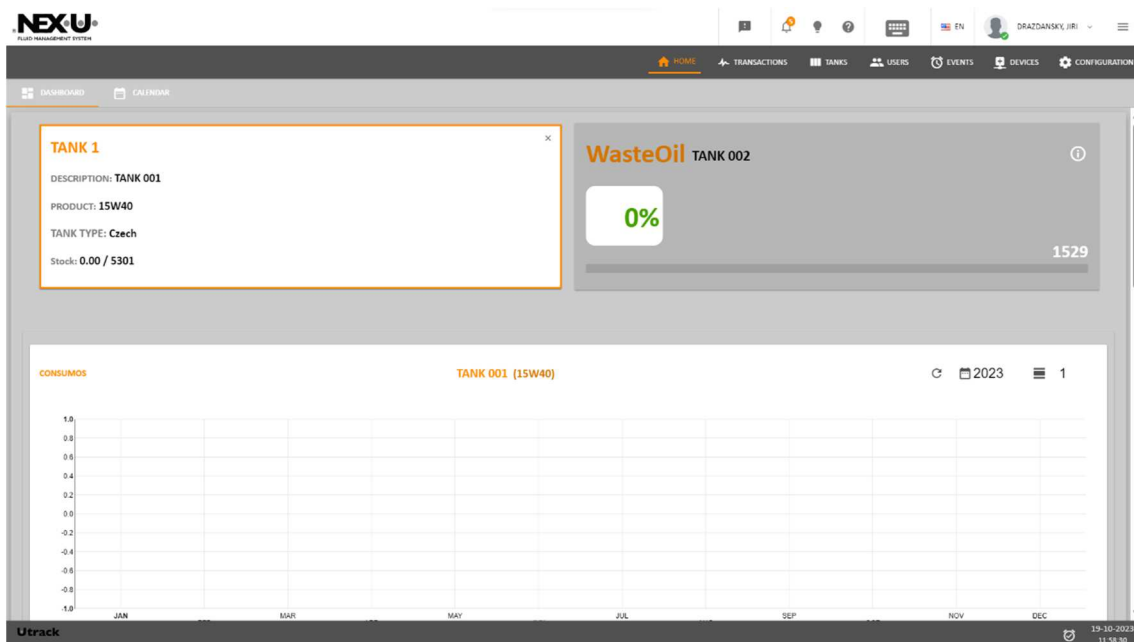

Below those sub-windows, you will find three more sub-windows. Left and right ones indicate the percentage of total fluid consumption since first U-Track installation. The one in the middle indicates the product variation referred to the previous month.

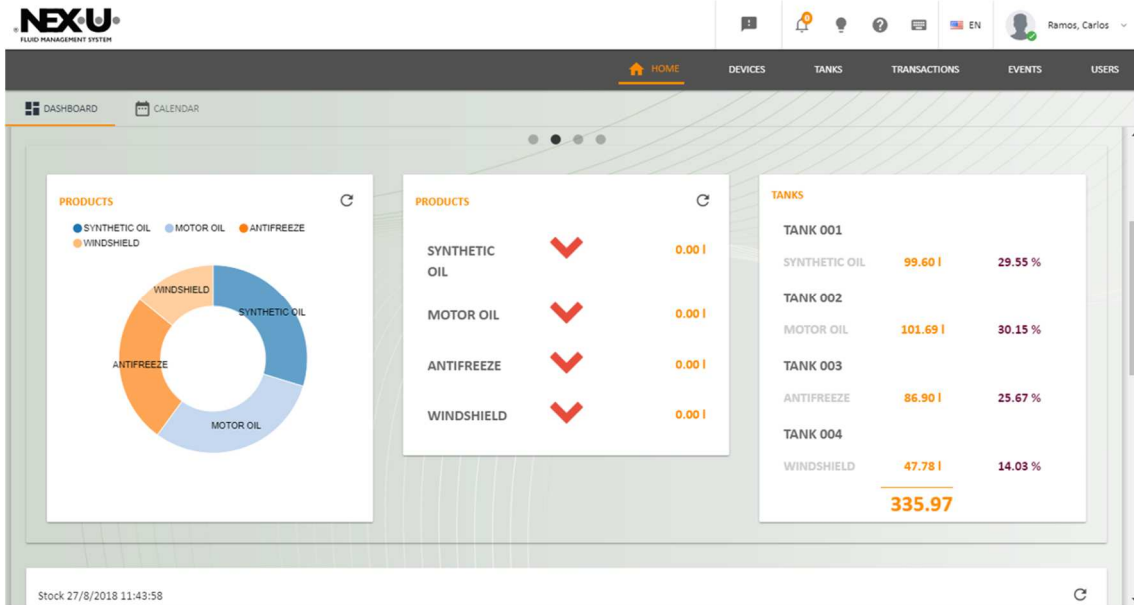

Below those sub-windows, you will find another sub-window in which you see the evolution of the liquid consumption.

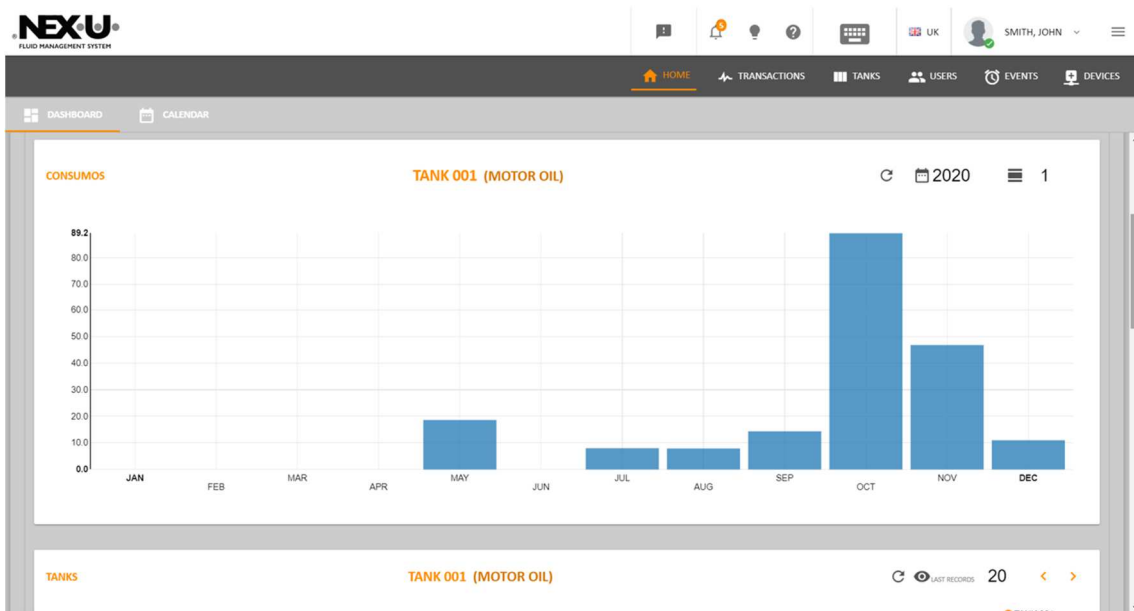

Below those sub-windows, you will find two more sub-windows. They indicate the percentage of total fluid consumption since first U-Track installation.

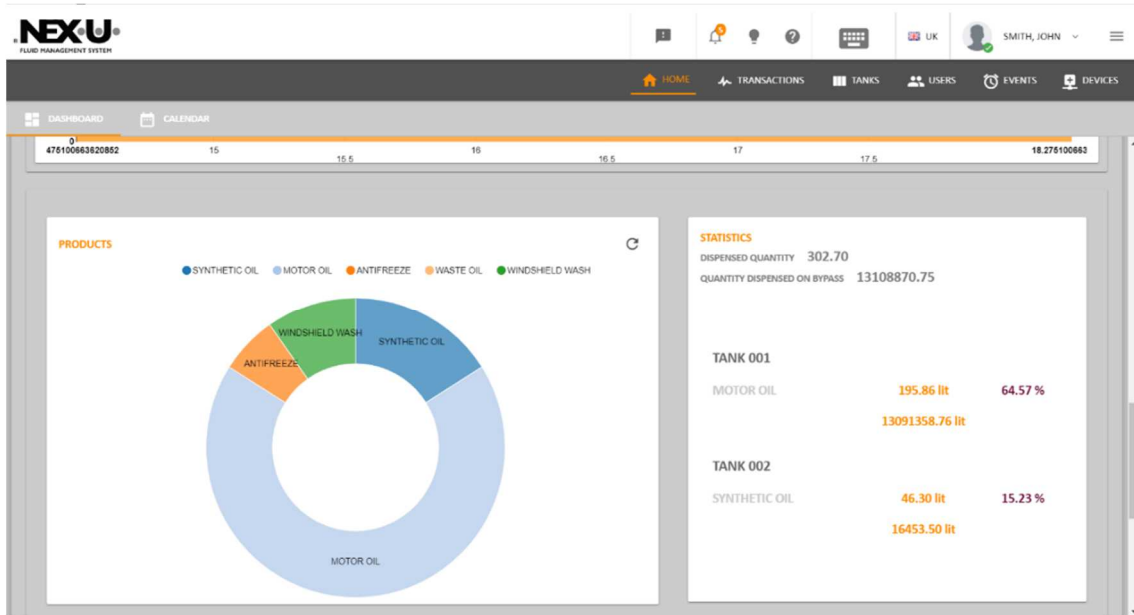

As well you can see in the upper right part the dispensed quantity in bypass mode

In the last part of the screen, you can see a short summary of the last transactions and the last events.

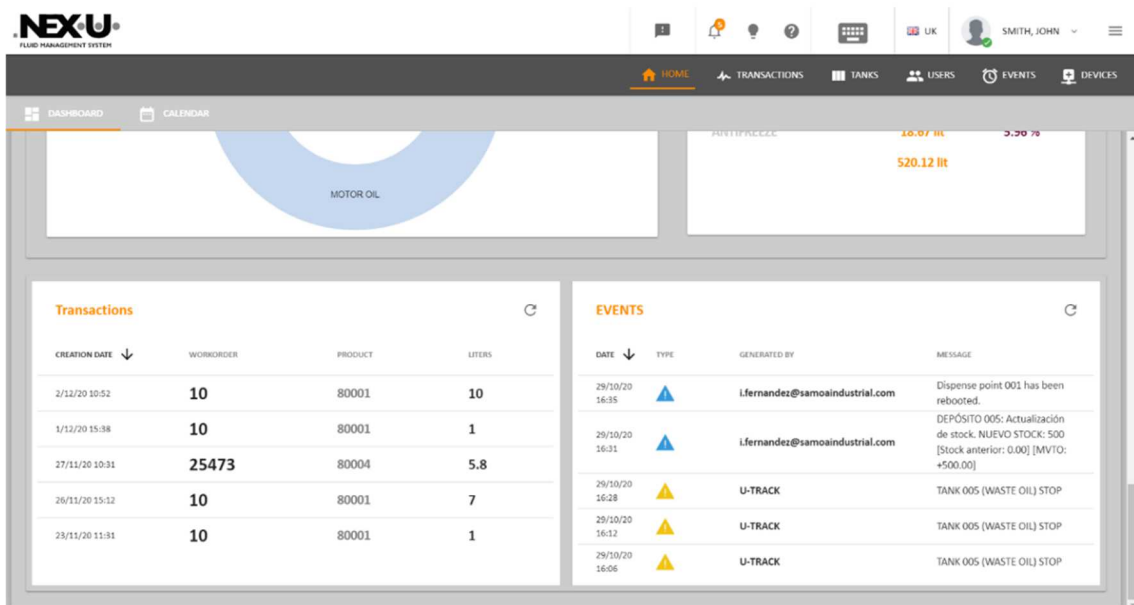

7.2 TRANSACTIONS

In the upper left part, of this screen you will find three options: Timeline, In Progress, Presets and API



If you press “Timeline” you will see all the active transactions (the ones which are being delivered or ready to be delivered)

ID	WORKORDER	DISPENSE POINT	PRODUCT	QUANTITY		CREATION DATE	CREATION BY	EXPORT
420	Redbh	UVALVE 006	MOTOR OIL	5,40	[5,40]	9/11/22 11:31	USER	
419	1234	UVALVE 007	ANTIFREEZE	2,00	[2,00]	27/10/22 17:16	USER	
418	Rty555	UVALVE 006	SYNTHETIC OIL	4,00	[4,00]	26/10/22 17:27	Samoa, Admin	
417	12345	UVALVE 009	ANTIFREEZE	5,50	[5,50]	26/10/22 17:28	USER	
416	TEST3	UVALVE 011	MOTOR OIL	0,00	[6,00]	26/10/22 17:21	USER	
415	hgg	UVALVE 001	MOTOR OIL	4,00	[4,00]	26/10/22 17:12	USER	
413	Gthjh	UVALVE 011	MOTOR OIL	0,00	[4,50]	26/10/22 17:09	Samoa, Admin	
412	1X4	UVALVE 011	MOTOR OIL	0,00	[5,40]	26/10/22 12:57	COMSTIOT, MIKAIL	
411	9876	UVALVE 011	MOTOR OIL	0,00	[7,00]	25/10/22 17:10	Samoa, Admin	
410	TEST7	UVALVE 011	MOTOR OIL	0,00	[4,00]	25/10/22 17:07	USER	
409	100	UVALVE 011	MOTOR OIL	0,00	[9,00]	25/10/22 17:04	USER	
408	fhhhh	UVALVE 009	MOTOR OIL	5,00	[5,00]	25/10/22 16:57	USER	
407	12345	UVALVE 011	MOTOR OIL	0,00	[1,50]	20/9/22 14:22	USER	
406	12345	UVALVE 002	SYNTHETIC OIL	4,95	[4,95]	20/9/22 14:10	USER	
405	Rty555	UVALVE 011	MOTOR OIL	0,00	[1,00]	29/9/22 19:00	USER	

In the upper left part of the screen you will see the number of displayed transactions (in this case 356). If you click on the square you will see all the transactions.

The columns show the following information:

First column: A consecutive number

Second column: Number of work order that is being delivered or ready to be delivered.

Third column: Dispensing point from which the product is being delivered or ready to be delivered.

Fourth column: Product that was delivered.

Fifth column: It shows two numbers. The first one shows the delivered quantity. The second one is the inserted quantity by the user when the work order was created.

Sixth column: It shows the transaction date of creation.

Seventh column: It shows who has created the transaction.

Eighth column: There is a flag which will be operative if there is a DMS link. If it is in green colour, it means that the transaction has been exported to the DMS. If it is in red colour, it means that the transaction has not been exported to the DMS. If it is in grey colour, it means there is no DMS,

If you press “In Progress” you will see all the active transactions (the ones which are being delivered or ready to be delivered)

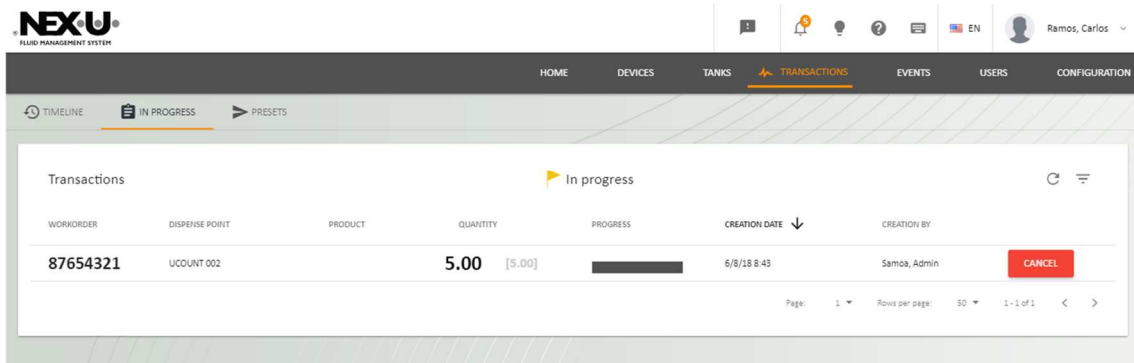

The columns show the following information:

First column: Number of work order that is being delivered or ready to be delivered.

Second column: Dispensing point from which the product is being delivered or ready to be delivered.

Third column: Product that being delivered or ready to be delivered.

Fourth column: It shows two numbers. The first one shows the delivered quantity. The second one is the inserted quantity by the user when the work order was created.

Fifth column: It shows a progress bar.

Sixth column: It shows the transaction date of creation.

Seventh column: It shows who created the transaction.

Eighth column: This button cancels the delivery. It gives an order to the system to close the solenoid valve and it cuts the delivery.

If you press “Presets” you will see all the transactions which have been created (kept in memory) but not delivered.

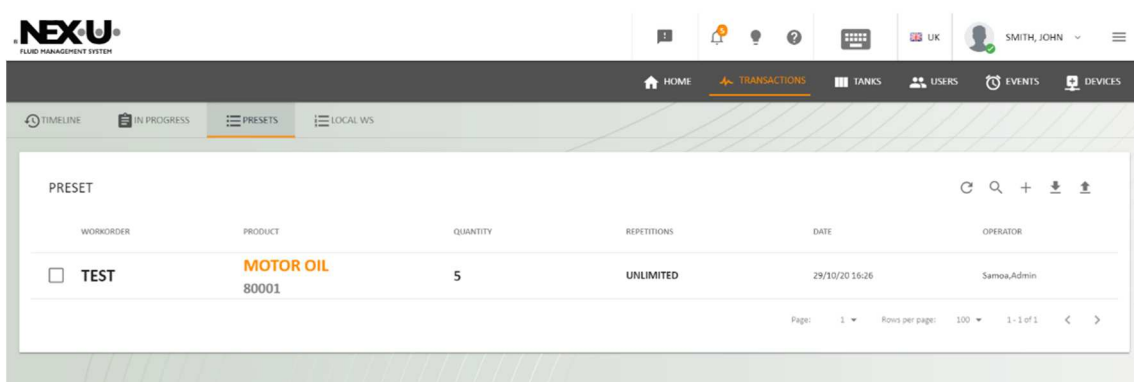

The columns show the following information:

First column: Number of work order that is being delivered or ready to be delivered.

Second column: Product / reference that is to be delivered.

Third column: Preset quantity that is to be delivered.

Fourth column: Number of repetitions allowed to be used under the work order.

Fifth column: It shows the transaction date of creation.

Sixth column: It shows who created the transaction.

In the upper left part, of this “Timeline” and “Presets” screens you will find several options



() refreshes the screen.

() allows to filter the transactions according to the text you insert.

() allows you to print the transactions. Once you enter this option, you can set the dates to print the transactions.

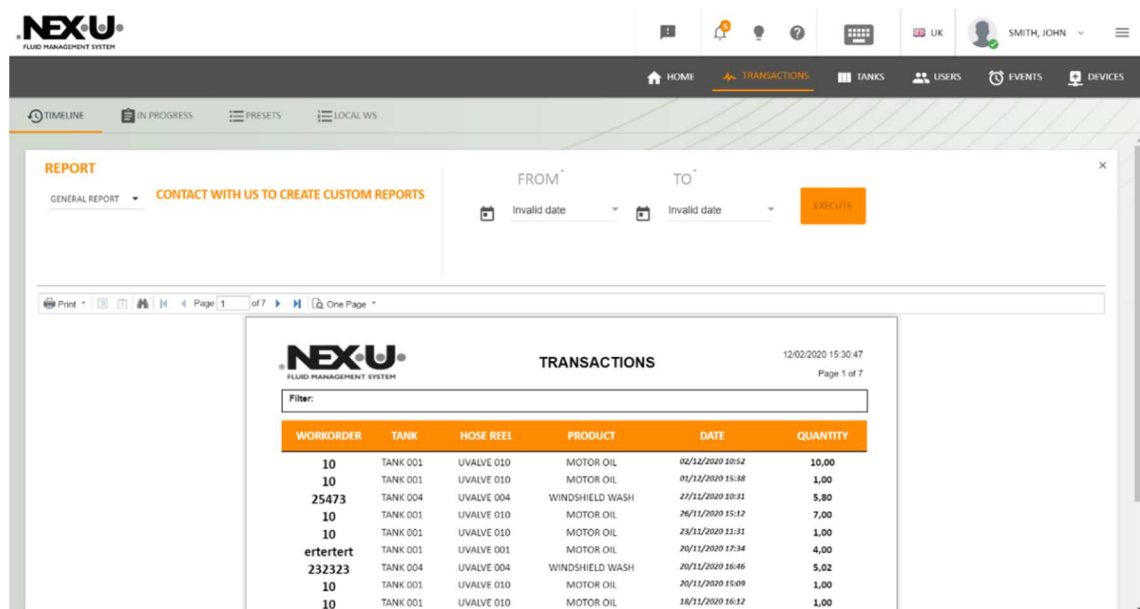

You can see that it is possible to make filters referred to a period (from / to)

() allows you to export the transactions to a csv file. You can see that it is possible to make filters referred to a period (from / to)

TIMELINE IN PROGRESS PRESETS LOCAL WS

Transactions

dd/mm/aaaa dd/mm/aaaa

ID	WORKORDER	DISPENSE POINT	PRODUCT	QUANTITY	CREATION DATE	CREATION BY	EXPORT
<input type="checkbox"/>	119	10	UVALVE 010	MOTOR OIL	10,00 [10,00]	2/12/20 10:52	Samoa, Admin
<input type="checkbox"/>	118	10	UVALVE 010	MOTOR OIL	1,00 [1,00]	1/12/20 15:38	Samoa, Admin

() allows you to export the transactions to a MS Excel file.

() allows you to export the transactions to a csv file. You can see that it is possible to make filters referred to a Workorder and a period (from / to)

TIMELINE IN PROGRESS PRESETS LOCAL WS

Transactions

25473 dd/mm/aaaa dd/mm/aaaa

ID	WORKORDER	DISPENSE POINT	PRODUCT	QUANTITY	CREATION DATE	CREATION BY	EXPORT
<input type="checkbox"/>	119	10	UVALVE 010	MOTOR OIL	10,00 [10,00]	2/12/20 10:52	Samoa, Admin
<input type="checkbox"/>	118	10	UVALVE 010	MOTOR OIL	1,00 [1,00]	1/12/20 15:38	Samoa, Admin
<input type="checkbox"/>	117	25473	UVALVE 004	WINDSHIELD WASH	5,80 [5,80]	27/11/20 10:31	Samoa, Admin
<input type="checkbox"/>	116	10	UVALVE 010	MOTOR OIL	7,00 [7,00]	26/11/20 15:13	Samoa, Admin

() lets you add new transactions (only for Presets)

Presets ✕

WORKORDER *
DFSDF



PRODUCT *
SYNTHETIC OIL

QUANTITY
12

REPETITIONS
SELECT VALUE...
NUMBER OF REPETITIONS *
4

SAVE
CANCEL TRANSACTION

() allows you to import / export Preset transactions from / to a csv file

For Preset transaction, you can tick any transaction and if you press , you will be able to change the preset work order and if you press , the transaction will be deleted.

1 item selected						
WORKORDER	PRODUCT	QUANTITY	REPETITIONS	Status	Close Date	Close By
<input type="checkbox"/>	699969	ANTIFREEZE	8	4		15/2/18 12:24 Samoa, Admin
<input checked="" type="checkbox"/>	690061	SYNTHETIC OIL	15	15		15/2/18 12:24 Samoa, Admin

Presets
✕

WORKORDER *
DFSDF

PRODUCT *
SYNTHETIC OIL

QUANTITY
12

REPETITIONS
SELECT VALUE...

NUMBER OF REPETITIONS *
4

SAVE
CANCEL TRANSACTION

If you press API, you will see the transactions made with a particular Taylor-made configuration. This menu is not relevant for standard installations.

7.3 TANKS

This screen shows a complete situation of the tanks.

TANKS							🔄	🔍	📄
	NUMBER	TANK	DETAILS	STATUS	STOCK UPDATE	U-TANK			
	1	TANK 001 MOTOR OIL 80001	STOCK: 0.00 CAPACITY: 1485 0 %	WARNING LEVEL: 300 STOP LEVEL: 100	OK				
	2	TANK 002 SYNTHETIC OIL 80002	STOCK: 1397.00 CAPACITY: 1485 94 %	WARNING LEVEL: 300 STOP LEVEL: 100	OK				
	3	TANK 003 ANTIFREEZE 80003	STOCK: 0.00 CAPACITY: 1485 0 %	WARNING LEVEL: 300 STOP LEVEL: 100	OK				
	4	TANK 004 WINDSHIELD WASH 80004	STOCK: 1388.06 CAPACITY: 1485 93 %	WARNING LEVEL: 300 STOP LEVEL: 100	OK				
	6	TANK 006 WASTE OIL 80005	STOCK: 0.00 CAPACITY: 1485 0 %	OK			001/1	↑↓	

Page: 1 - Rows per page: 50 - 0 of < >

First column: There is a little picture of the device (tank in this case).

Second column: The tank address is shown.

Third column: It shows if the tank is for delivery (fresh product) or recovery (waste product)

Fourth column: It shows a combination of the name of the tank and the name & reference of the fluid that is contained in the tank.

Fifth column: It shows the contained quantity, the maximum capacity and the percentage. For instance, for tank 1 the contained quantity 200 litres, the maximum quantity is 2000 litres and the percentage is 10 %.

Sixth column: It shows the warning and the stop levels set in the configuration menu.

Seventh column: It shows the status of the tank in case which are

OK – If level is above warning level.

ALARM – If level is between warning level and Stop level

STOP – If level is in stop point

BYPASS – If the bypass key has been activated and the air solenoid valves are open.

UNKNOWN – If there is a connected probe and there is any fault.

Eighth column: If you press a pop-up window appears and you can see the stock level (if a U-Tank is not installed. If it is installed, the icon will be grey colour)

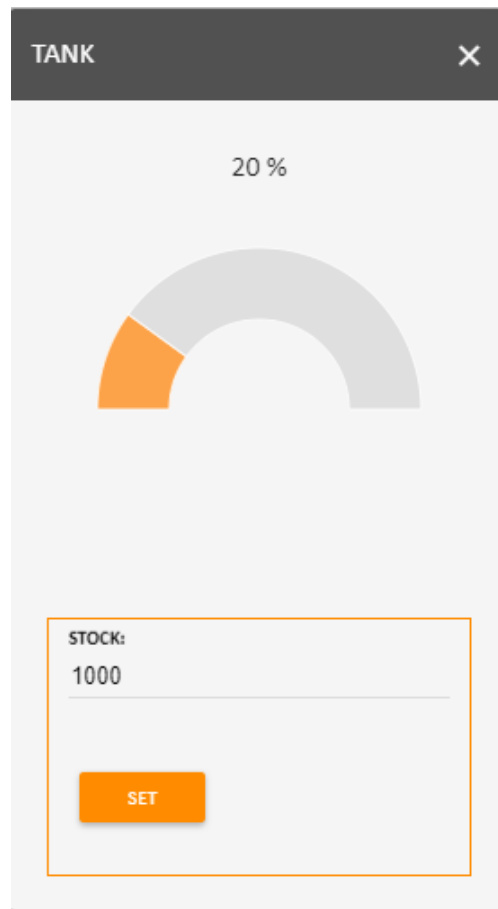

You can change the stock level and then you must press the SET button. NOTE: The maximum quantity has to be lower than the capacity of the tank.

The upper part of the pop-up window shows the percentage of the filling percentage and a semicircle that shows the filling sector.

Ninth column: It shows if there is a connected probe or not. If so, an icon will appear

 : Volumetric Probe

 : Contact Probe

7.4 USERS

In this screen you can create / modify / delete users. There are two different kinds of users:

Administrator: It has got the manager rights and can access all the windows of chapter 7. This user will NOT have access to the configuration menu. The front page will NOT include this option.

Operators: It has got rights only for dispensing work orders and if you insert the User / Password in the U-Track, it will go to the Virtual Keypad (see chapter 8)

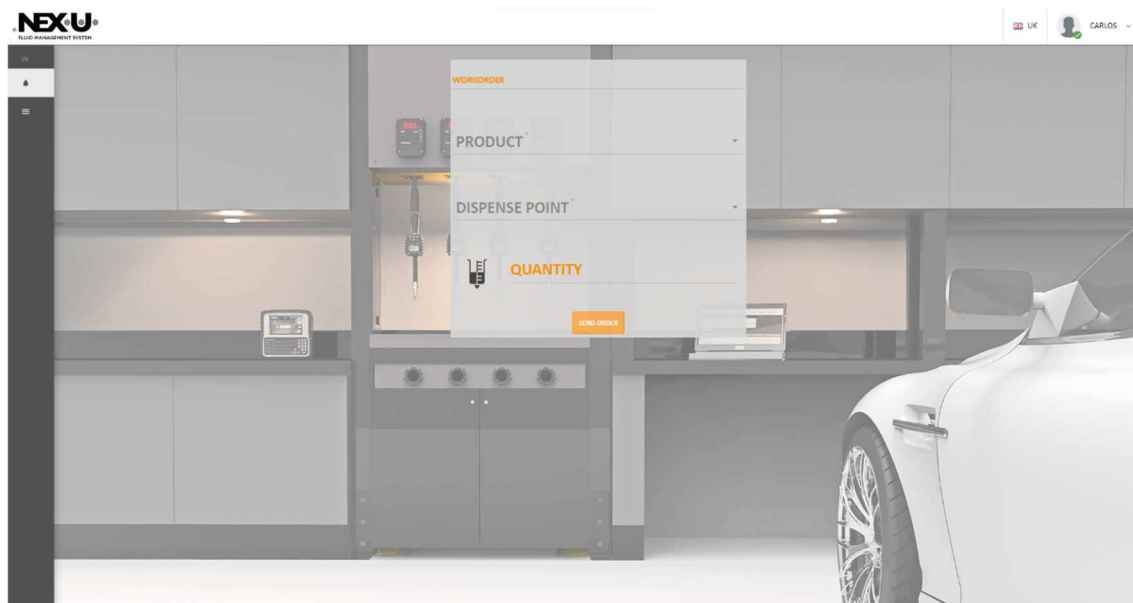

If you want to create a new user, you must press **+**. This will open a new window which will be different if you want to create an administrator or an operator.

Administrator:

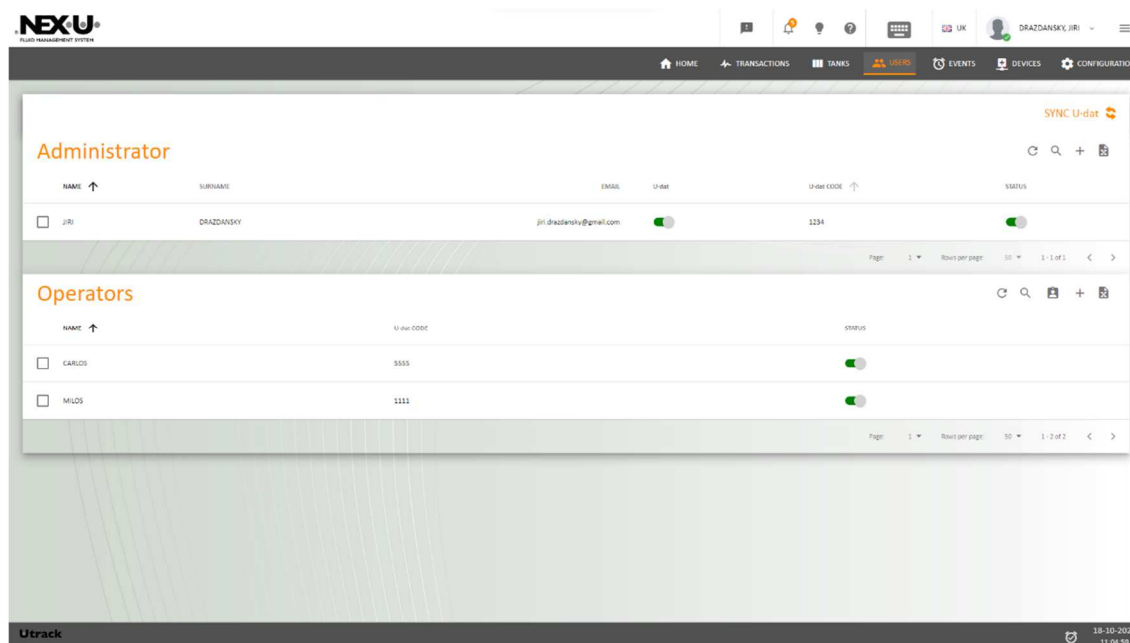

2024_07_24-10:02

You can set the following parameters

Name / Surname / Email. These fields are compulsory.

U-Track Password. It must contain at least one number and one capital letter. Minimum number of characters must be eight.

Send tank level warnings by mail: If you tick this option, an email will be sent to the user when a level alarm in the tanks is reached.

Authorization for dispensing. You can set if this user can deliver oil in the U-Dat. If you choose YES, the system will ask for a code.

As well, you can choose the interface language by clicking the flag.

You can set the status of the user. For instance, you can disable it when the user leaves the company.

As well you will see this icon  If you click on it, all the Administrators / Operators will be sent to the installation.

The screenshot shows a web form titled "Form" with a close button (X) in the top right corner. The form contains the following elements:

- NAME ***: A text input field with a small flag icon and "ES" next to it.
- SURNAME ***: A text input field.
- EMAIL ***: A text input field.
- U-TRACK Password. Must contain at least 1 number and an uppercase letter ***: A text input field.
- Send tank level warnings by mail**: A checkbox.
- Authorization for dispensing**: A dropdown menu currently showing "NO".
- Status**: A checked checkbox.

At the bottom of the form, there are two buttons: "SAVE" (orange) and "CANCEL" (grey).

Operators:

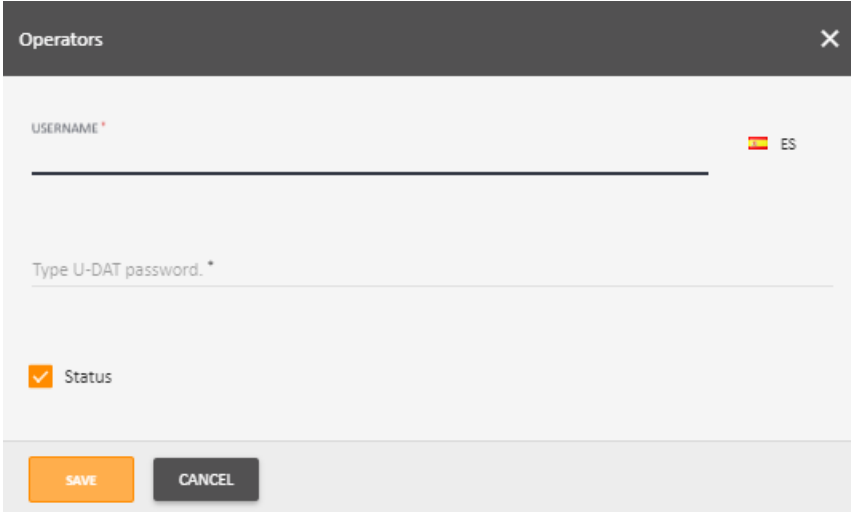

Operators

USERNAME * ES

Type U-DAT password. *

Status

SAVE CANCEL

User name. This field is compulsory.

U-Dat Password. It is recommended to insert numerical digits.

As well, you can choose the interface language by clicking the flag.

You can set the status of the user. For instance, you can disable it when the user leaves the company.

7.5 EVENTS

In the upper left part, of this screen you will find two options: New and Timeline



If you press “New” you will see all the new events that took place in the system.

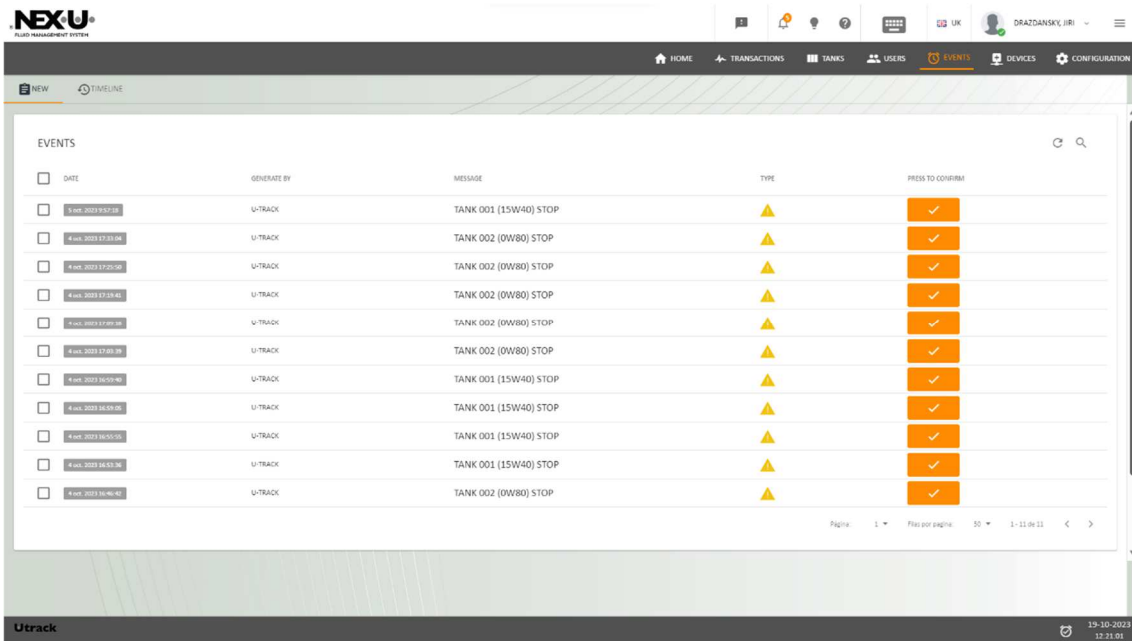

If you press “Timeline” you will see a timeline of all the events, when they were confirmed and who confirmed them.

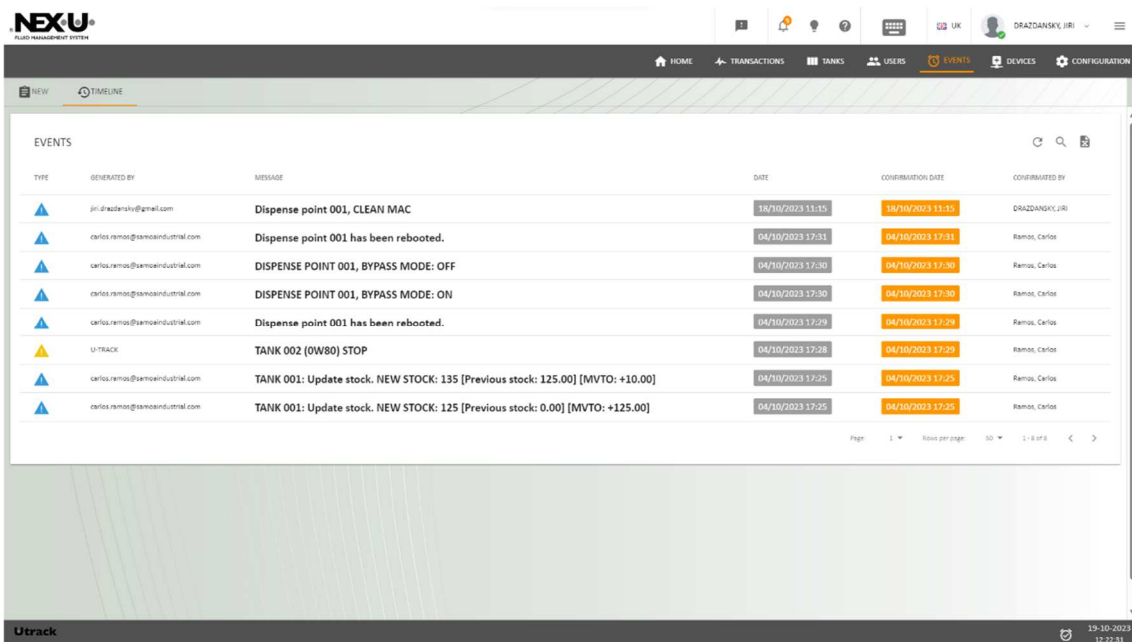

7.6 DEVICES

7.6.1 DISPENSE POINT

This screen shows a complete situation of the connected devices of the installation. Also, in this window you can change some of the parameters. These are the labels you can find

INFO: It will show a snapshot of the complete installation. It will show the association between tanks, products and dispensing points.

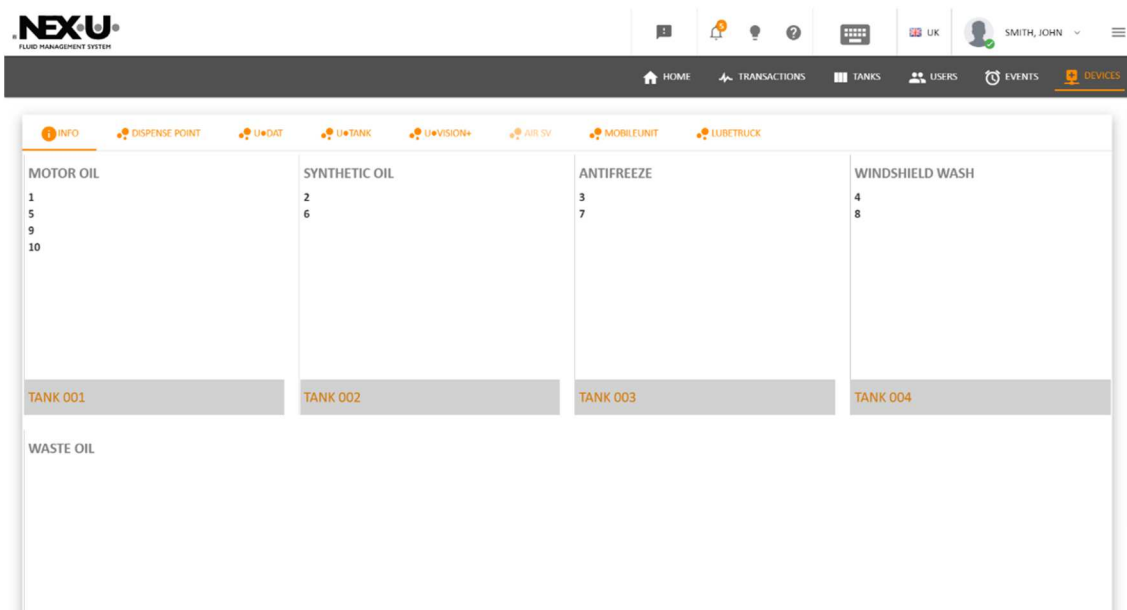

DISPENSE POINT: It shows the configuration of the dispensing points.

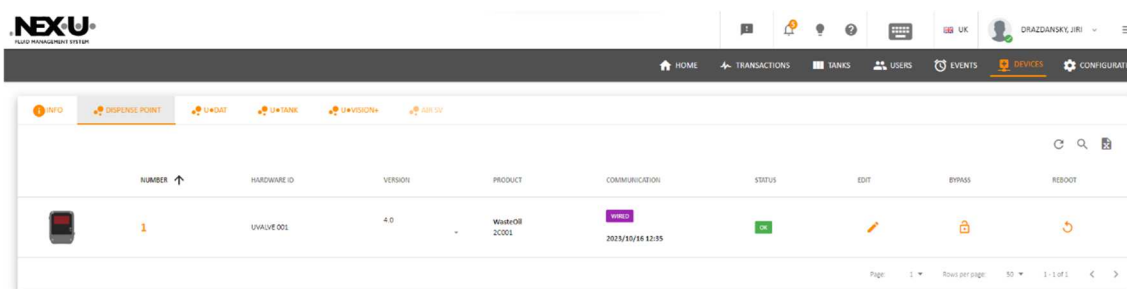

First column: There is a little picture of the device.

Second column: The address is shown. It represents the number of the local parameter.

Third column: It shows the description of the device. This description is the one that was set in the configuration menu.

Fourth column: It shows the loaded device firmware version. As well there is an option for enabling (BLE 1) or disabling (BLE 0) Bluetooth® feature of the unit and for Cleaning the acquired MAC of the U·Vision or U·Vision+.

Fifth column: It shows the product that is delivered (if the device is a delivery one) or shown (if the device is a display one)

Sixth column: It shows the way the device is connected. It can be either wired or Wi-Fi (Wireless) linked.

WARNING: If Wireless is shown, it could not mean that the device is wireless connected. It means that it the device is communicating to the U·Net through a device that is wireless connected.

A date/time is shown as well. This indicates the last moment in which right communication was held between the U·Net and the device. If date/time is old (more than a few minutes), it means that there is something wrong with the communication.

Seventh column: It shows the status of the device. In the above screenshot you can see that all of them are OK (fully operational). If BYPASS is shown, it means that the solenoid valve of that device is open via software (see Ninth column)

Eighth column: In this column you can edit some of the device parameters. If you press the icon  , a pop-up window appears and you will be able to change some of the parameters. For U·Valve / U·Count you can change the following parameters

- Pulse meter value:

This parameter corresponds to the nominal value of the pulse meter. For example, the U·Valve incorporate a pulse generator of 328 Pulses per litre. The allowed range is 10 to 1000 pulses per litre.
- SV aperture delay

Regulates the time the solenoid valve takes to open after the transaction confirmation. The allowed range is 0 to 600 seconds.
- Suspension time

It regulates the pause time without receiving pulses from the pulse generator. If the transaction is interrupted for a time longer than this value, the transaction is counted as finished and the solenoid valve closes automatically. The allowed range is 0 to 900 seconds.

- **Top Up time**
It regulates the waiting time after the initial transaction is completed, making it possible to do an additional topping in the same transaction although the preset quantity is achieved. After this stated time, it is not possible to dispense an additional quantity to the transaction and it is considered as completed. For example, we have ordered 4 litres and after that these 4 litres have been dispensed, this is the time available for making an additional topping to the original transaction (for example another 0.2 litres, because even if we initially thought that the crank case had 4 litres, when the 4 litres are dispensed and the dip stick is checked we see that we need to fill in a little more). During this time, the display integrated in the U·Valve or U·Count will show “top” giving the possibility to extend the transaction. The allowed range is 0 to 1800 seconds.
- **Remote Display 1 / Remote Display 2**
If any U·Views are installed, it is possible to show the delivered quantity in up to two U·Views. You can set the U·View number in this menu.
- **Max Quantity**
In this option it is possible to set the maximum quantity that can be delivered through this device. The allowed range is 0 to 999 litres.
- **K Factor**
This is the calibration factor that is automatically set when the calibration procedure is followed in the device. In any case, it is possible to change it manually if the value is already known. The allowed range is 500 to 1500.
- **Display Quantity**
Activates or deactivates the showing of the transaction on the display integrated on the U·Valve or U·Count. If this option is not chosen, “falling angles” are showed on the display during the transaction.

Ninth column: It shows if the device is in bypass mode via software or not. If it is not, the padlock is closed. If so, it is open. You can set the device to bypass mode (open solenoid valve) by clicking on the padlock.

Tenth column: If you press  the device gets rebooted just in case it gets frozen.

In the upper right part of the window there are three icons.



The first one refreshes the readings; the second one allows to make a search in the table and the third one allows to export data to a MS Excel spreadsheet.

F18		fx		
	A	B	C	D
1	NAME	VERSION	PRODUCT	
2	UVALVE 001		SYNTHETIC OIL	
3	UVALVE 002		MOTOR OIL	
4	UVALVE 003		ANTIFREEZE	
5	UVALVE 004		WINDSHIELD	

For U-Link, it is not possible to change any parameters.



First column: There is a small picture of the device.

Second column: The address is shown. It represents the number of the local parameter.

Third column: It shows the description of the device. This description is the one that was set in the configuration menu.

Fourth column: It shows the loaded device firmware version.

Fifth column: It shows the product that is delivered (name and reference)

Sixth column: It shows the way the device is connected. For U-Link, obviously it will be wireless (ZigBee®).

A date/time is shown as well. This indicates the last moment in which right communication was held between the U-Net and the U-Link. If date/time is in the past (more than a few minutes depending on the installation size), it means that there is something wrong with the communication.

Seventh column: It shows battery load of the device.

Eighth column: In this column you can see the ZigBee® module MAC address.

7.6.2 U-DAT

This screen shows a complete situation of the connected U-Dat. Also, in this window you can change some of the parameters.

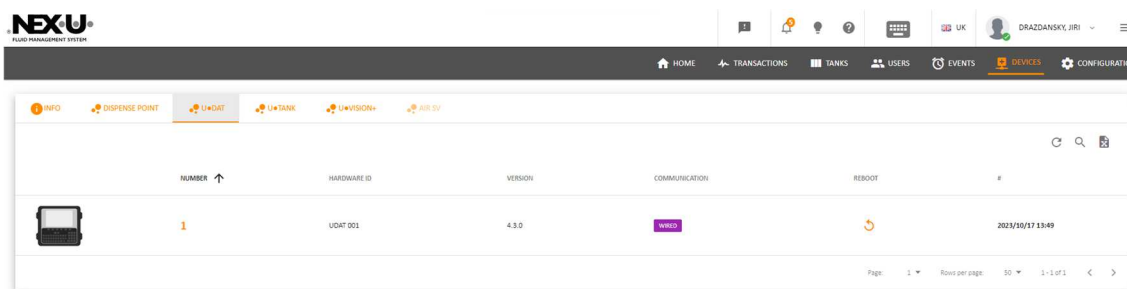

First column: There is a little picture of the device.

Second column: The address is shown. It represents the number of the local parameter.

Third column: It shows the description of the device. This description is the one that was set in the configuration menu.

Fourth column: It shows the loaded device firmware version.

Fifth column: It shows the way the device is connected. It can be either wired or Wi-Fi (Wireless) linked.

WARNING: If Wireless is shown, it could not mean that the device is wireless connected. It means that it the device is communicating to the U-Net through a device that is wireless connected.

Sixth column: If you press  the device gets rebooted just in case it gets frozen.

Seventh column: A date/time is shown as well. This indicates the last moment in which right communication was held between the U·Net and the device. If date/time is old (more than a few minutes), it means that there is something wrong with the communication.

7.6.3 U·TANK

This screen shows a complete situation of the connected U·Tanks. Also in this window you can change some of the parameters.

INFO	DISPENSE POINT	U·DAT	U·TANK	U·VISION+	AIR DV	MOBILEUNIT	LUBETRUCK
			NUMBER ↑	HARDWARE ID	VERSION	BYPASS	#
			1	UTANK 001	1.8	OK	2020/12/02 17:51

Page: 1 Rows per page: 50 1 - 1 of 1

First column: There is a little picture of the device.

Second column: The address is shown. It represents the number of the local parameter.

Third column: It shows the description of the device. This description is the one that was set in the configuration menu.

Fourth column: It shows the loaded device firmware version.

Fifth column: It shows the status of the device. In the above screenshot you can see that all of them are OK (fully operational). If BYPASS is shown, it means that the solenoid valves connected to that device are open

Sixth column: A date/time is shown as well. This indicates the last moment in which right communication was held between the U·Net and the device. If date/time is old (more than a few minutes), it means that there is something wrong with the communication.

7.6.4 U·VISION+

This screen shows a complete situation of the connected U·Vision+. Also, in this window you can change some of the parameters.

DISPENSE POINT	U·DAT	U·VISION+	AIR DV		
		NUMBER ↑	HARDWARE ID	DISPENSE MODE	UPDATE
		13	U·VISION+ 013	PRESET	UPDATE

1 - 1 of 1

First column: There is a little picture of the device.

Second column: The address is shown. It represents the number of the local parameter.

Third column: It shows the description of the device. This description is the one that was set in the configuration menu.

Fourth column: It shows the dispense mode for the U·Vision+ (you can choose between NORMAL and PRESET)

Fifth column: It shows the update button.

7.6.5 AIR SV

In this screen you can set the date/time in which the solenoid valve is open in automatic mode. You can set it to manual mode by choosing the option (AUTOMATIC / MANUAL)

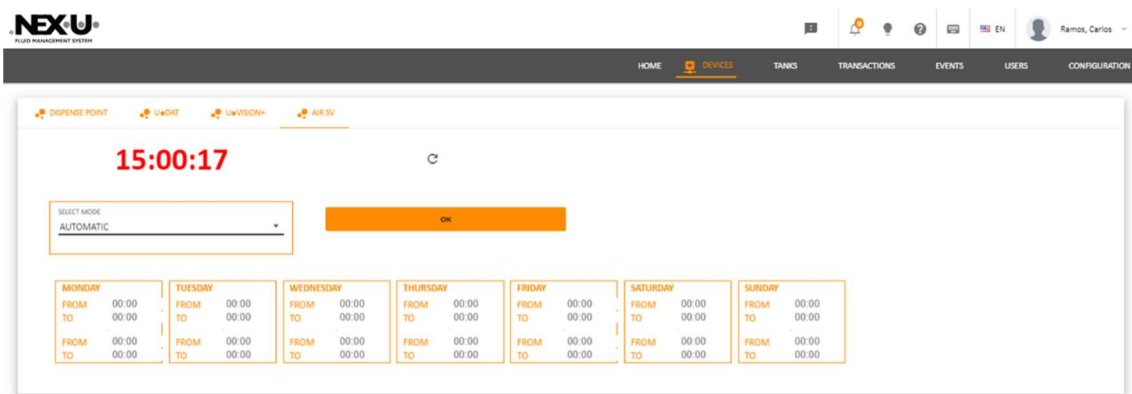

7.7 CONFIGURATION

You will be able to change some parameters of the installation.

7.7.1 PRODUCTS

In this screen can change some parameters of the products of the installation.

Press the icon **+** (upper right part) and a popup window appears.

Part Number: This is the part number of the product and must be the same as the one defined in the customer DMS (This parameter is compulsory)

Name: This is the name of the product and has to be the same as the one defined in the customer DMS (This parameter is not compulsory)

Provider: This is the provider of the product (This parameter is compulsory)

Density: This is the density parameter and must be inserted in kg/cm3. This parameter is compulsory if the installation has a U-Tank.

Viscosity: This is the viscosity parameter and has to be inserted in cPs

Unit: In this screen you must define the unit you want to work. There are two options. Litres and Gallons.

Once you have finished, press **SAVE** to save the changes.

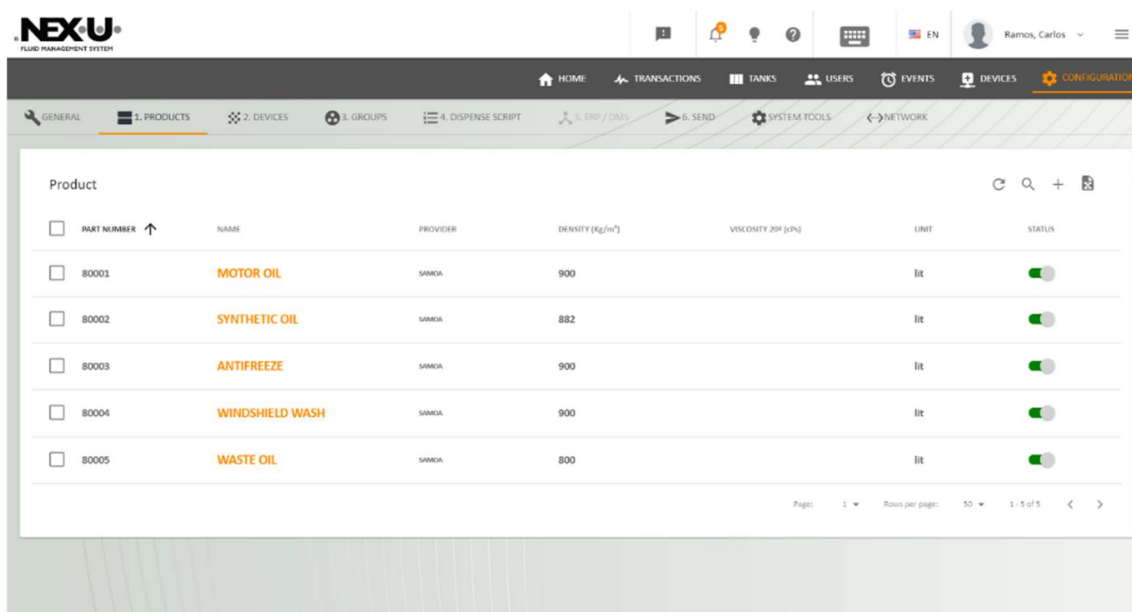

At the end of the line, you can see a column with “Status”. If it is active (green) it means that the product is active and it is part of the installation.

If the customer stops using that product, you have to create a new one and deactivate the previous one (click in the button and it will be red). The product that is not used any more will not be removed from the system.



If you want to change any parameters of any product preciously created, please tick the line and press  (in the right part of the screen) to make the changes.

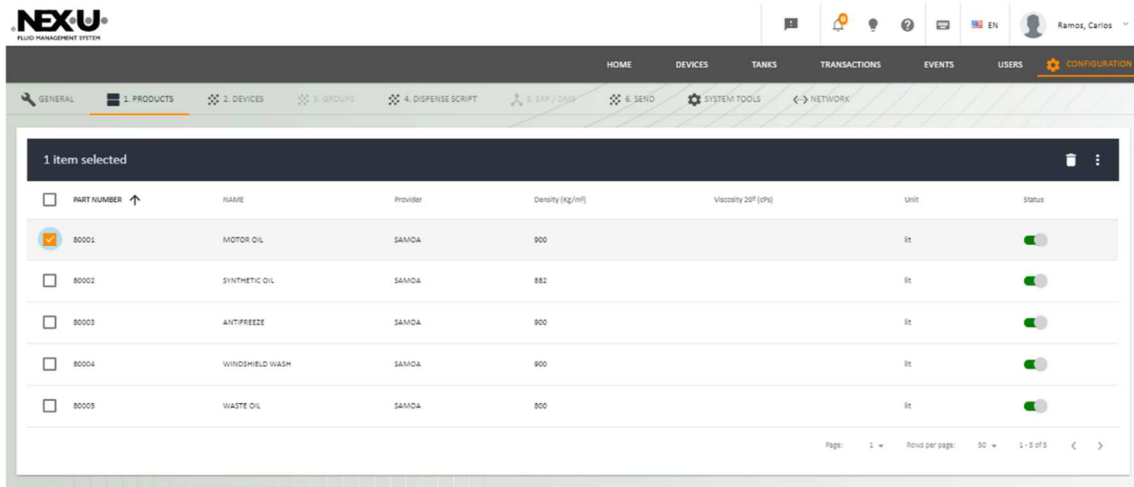

In this menu you will be able to make groups with certain privileges to restrain the ability of dispensing products or using hose reels or keypads.

Press + and a Pop-up window will appear

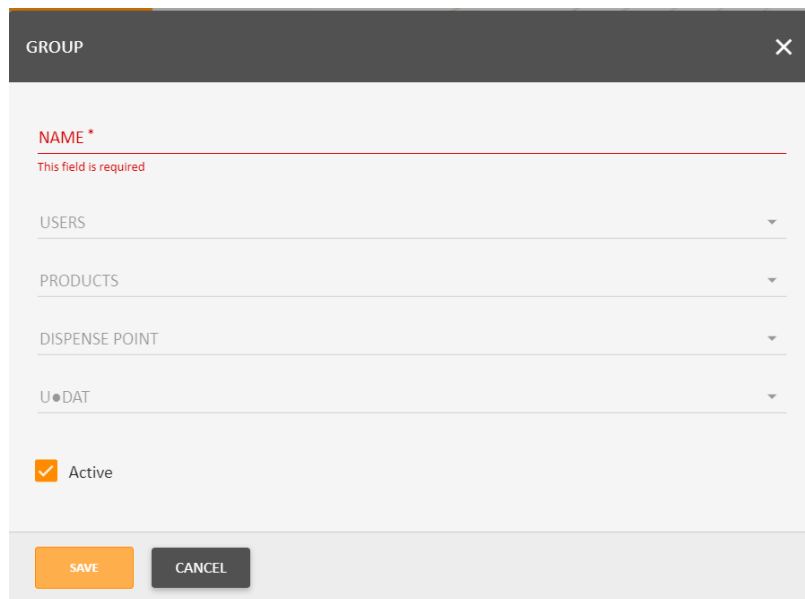

Name: You can make a brief description of the group (i.e.: Mercedes-Benz Users)

Users: You can set the customers in this group

Products: You can set the products that the customers can dispense

Dispense Point: You can set the dispense points in which the customers can dispense

U-Dat: You can set U-Dat in which the customers can dispense

Active: You can enable or disable this group by ticking/unticking this option.

7.7.3 DISPENSE SCRIPT

With this option you will set the way you want to insert the job orders as well as more data.

On the left part of the screen (Dispense Script) you can see which are the required data when you insert a job order. If you want the data to be required, you have to move the button to the right so that the colour gets green.

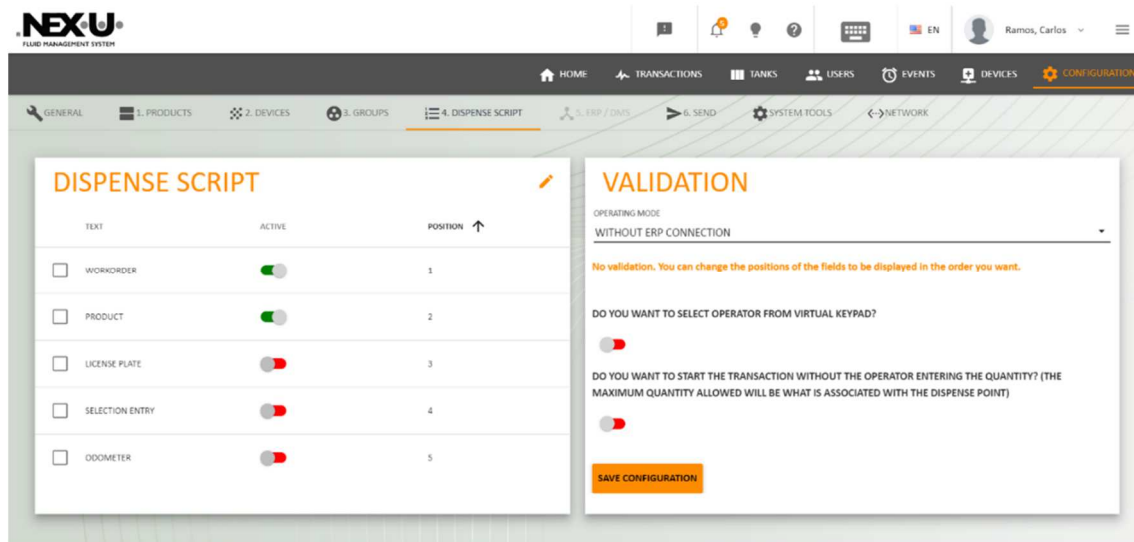

If you click on the tick of any text and then , a new screen will appear and you will be able to choose the key position in which the text appears when the job order is inserted.

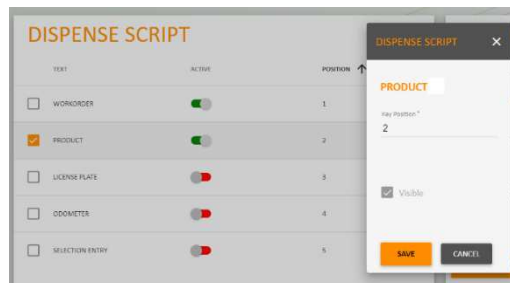

On the right part of the screen (Validation) you can set how you want to work. There are several options.

- Without ERP connection: No validation from the Data Management System (DMS). You can change the positions of the fields to be displayed in the order you want.

You can select if an operator can be selected from virtual keypad.

As well, you can choose to deliver oil without inserting a quantity

- Workorder Validation: Before the transaction is allowed, the work order is sent to the DMS for validating. If the DMS confirms that the work order exists, the user may continue with the process, otherwise access is denied.

With this option you can choose to deliver oil without inserting a quantity

As well, you can set an Override code just in case you need to make a dispense without entering a job order.

- Preset: (Validated Preset Transactions). The user types the work order and selects the product. The system searches in the local database and check if it exists. If it exists, the

required quantity is returned. The same workorder with different products cannot be used, in that case use the PRELOAD mode

- ERP Preset: The user types the work order and selects the product. The system asks DMS if the order is opened and associated with that product. If it is, the DMS set the required quantity.
- Preset Direct: The user concatenates work order and dispense point in the work order field (XXXXX.YYY). The system sends the information to the DMS and the DMS, if the information is validated, returns the maximum quantity.
- Product Preload: The user types the work order and selects the product. The system searches in the local database and check if it exists. If so, the required quantity is returned.

There is an option in which the user can modify the preset quantity.

- Menu Pricing: The DMS sends work orders to the local database via web services. The system validates the work order and the DMS asks for the dispensed quantity after the transaction is completed.
- API: The DMS sends work orders to the local database via web services. The system validates the work order and the DMS asks for the dispensed quantity after the transaction is completed.

You can set an Override code just in case you need to make a dispense without entering a job order.

- CDK Global: Before the transaction is allowed, the work order is sent to the CDK GLOBAL for validating. If the DMS confirms that the work order exists, the user may continue with the process, otherwise access is denied.

With this option you can choose to deliver oil without inserting a quantity

As well, you can set an Override code just in case you need to make a dispense without entering a job order.

- All in One: Before the transaction is allowed, the work order is sent to the CDK GLOBAL for validating. If the DMS confirms that the work order exists, the user may continue with the process, otherwise access is denied.

As well, you can set an Override code just in case you need to make a dispense without entering a job order.

- Asanet: Asanet sends the list of work orders and positions, with associated product. See the transactions in the preset list. Format WORKORDER.POSITION.

7.7.4 SYSTEM TOOLS

In this menu you have four options.

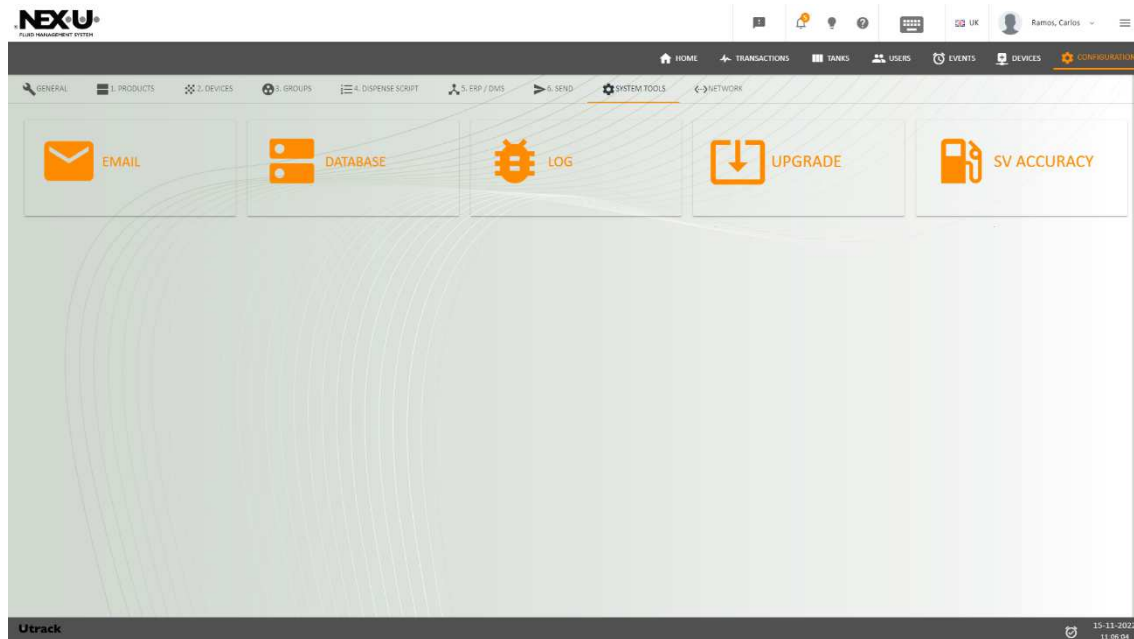

EMAIL: With this menu you can check if the mail delivery option is properly set. You have to say if this email is either Cloud-based or SMTP. In this case, apart from a valid email, you will have to insert all the SMTP parameters. If the email setting is properly made, you will receive an email from nexulinter@gmail.com



DATABASE: You can find two different characteristics

Query: You can set several options

- **Customer ID:** You can set the text that will appear in the upper left part of the home screen.
- **Show / Hide Disabled users:** If any users / administrators are disabled, this option enables hiding of those users / administrators in the list.
- **VK User (Session time):** Time in which the virtual keypad is closed once the transaction is completed.
- **Close VK sessions:** It closes all the virtual keypads which are open at that moment.
- **Decimal separator:** It sets the decimal separator. Either “,” or “.”
- **Delete TR in progress:** It deletes the transactions in progress which are stuck in the process (due to a power cut, for instance)
- **Delete Transactions:** It deletes the transactions already made. This is useful when you want to delete the test transactions in the commissioning process.
- **Delete Events:** It deletes the events already made. This is useful when you want to delete the test transactions in the commissioning process.
- **Delete Comdevice:** It restart the devices communication parameters.
- **API Token:** Required data when Taylor-made configuration is made. No data must be inserted if you are creating an standard configuration.

To get into that option, you have to click on the left orange icon (i. e. )

Backup: You can set two options:

- Create: If you press the icon , a configuration and transactions backup is made in the USB dongle inserted in the rear part of the U·Net (NOTE: The U·Net automatically back up the configuration and transactions data weekly)
- Restore: If you press the icon , a configuration and transactions backup is uploaded from the USB dongle inserted in the rear part to the U·Net. WARNING: All the data in the U·Net will be deleted once you make this action.

LOG: It shows the configuration changes traceability.

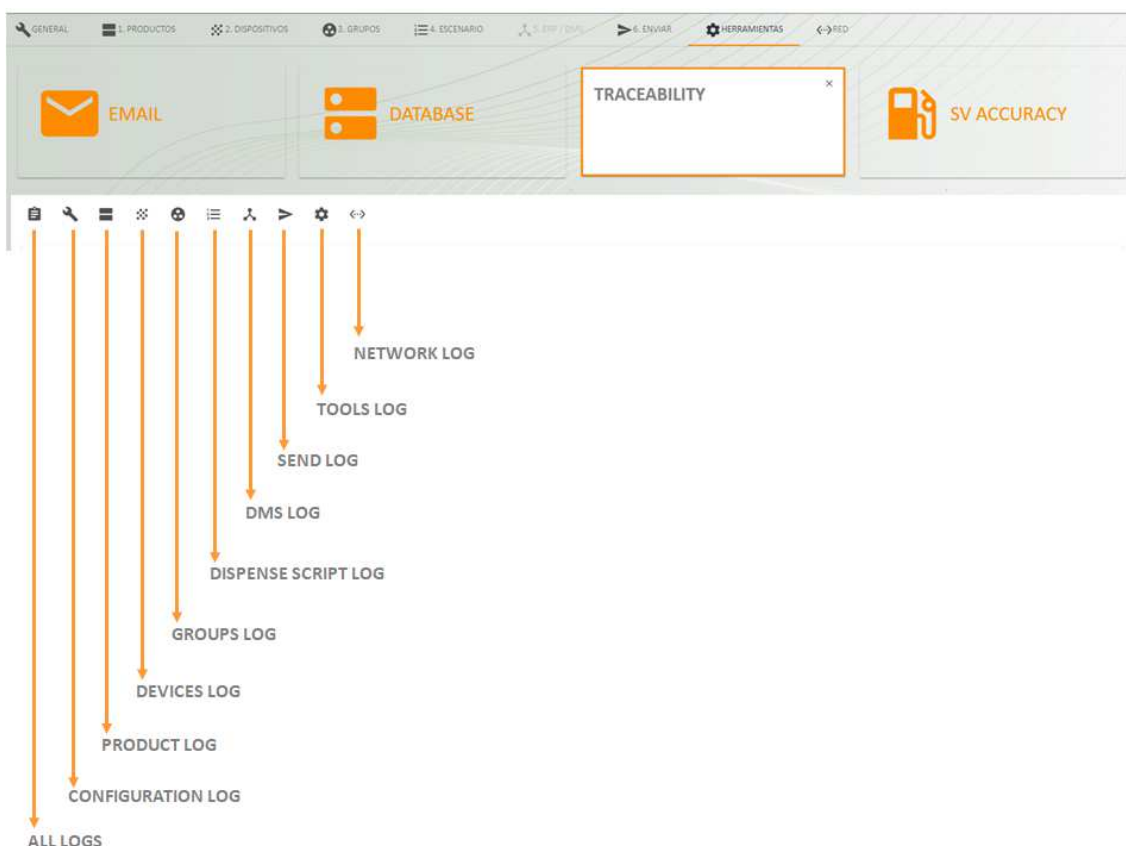

UPGRADE: Not available in this version.

SV ACCURACY: With this option you can set a more precise calibration.

The first step is to select the dispense point. After pressing PRESS TO GET PARAMETERS button to get the dispense point settings.

The software will show PPL and K FACTOR and ask for the dispensed quantity over the required quantity.

With that information the system calculates anticipation parameter and by pressing the **SEND** button it is set in the configured unit.

8 QUICK PANEL

In the upper part there is a menu with several options

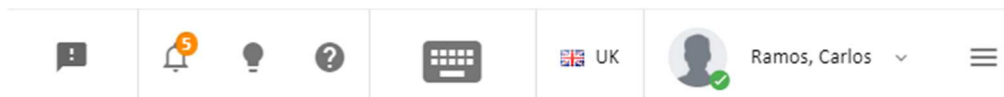

The first icon () shows the U·TRACK version and allows a NEX·U: CANBUS reset.

v4.2.0 04/2024

CANBUS RESET

The second icon () shows the last five alarms.

Alarms last 5 days (5)

	CUVE001(10W30) 1500 2018-07-14T23:25:25.409Z	
	CUVE001(10W30) 1500 2018-07-14T23:25:24.361Z	
	CUVE001(10W30) 1500 2018-07-14T23:25:23.941Z	
	CUVE001(10W30) 1500 2018-07-14T23:25:22.457Z	
	CUVE001(10W30) 1500 2018-07-14T23:25:21.496Z	

The third icon () shows a calendar with the events that took place in the chosen period.

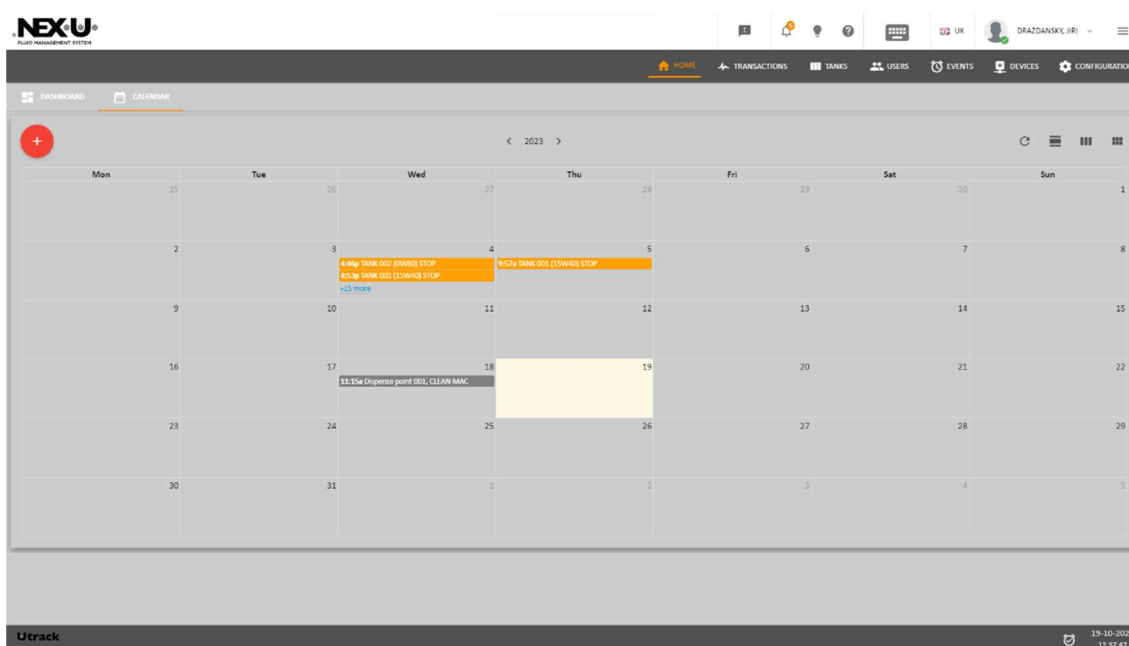

2024_07_24-10:02

The fourth icon () shows the help menu

The fifth icon () opens the virtual keypad (see chapter 8)

The sixth icon allows changing the interface language for the U·Track (Note: This language can be set for each user)

The seventh icon allows changing the profile (My profile), shows the status and or closes the session (Logout).

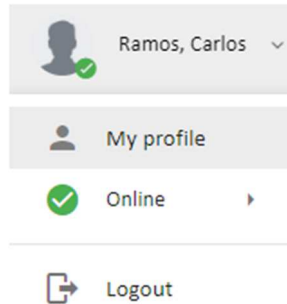

If you choose My profile, you will be able to change all the data of the current user.

The image shows a 'Form' dialog box for editing user data. The fields are as follows:

- NAME ***: CARLOS (with a UK flag icon on the right)
- SURNAME ***: RAMOS
- EMAIL ***: carlos.ramos@abcd.com
- U-TRACK Password. Must contain at least 1 number and an uppercase letter ***: *****
- Send tank level warnings by mail
- Authorization for dispensing**: YES (dropdown menu)
- Type U-DAT password.**: *****
- Status

At the bottom of the form are two buttons: 'SAVE' (orange) and 'CANCEL' (grey).



The eight icon () shows two different options: INFO and USERS

INFO: You will see date, number of available Virtual Keypads and UNET MAC

USERS: You will see the number of administrator currently using the system, number of open Virtual Keypads (VK) and number of APP users (option not available in August 2024)

9 VIRTUAL KEYPAD

In the upper right part of the window, you can find this icon: . This is the virtual terminal and it allows creating transactions to deliver product. If you click the icon, you will see this window

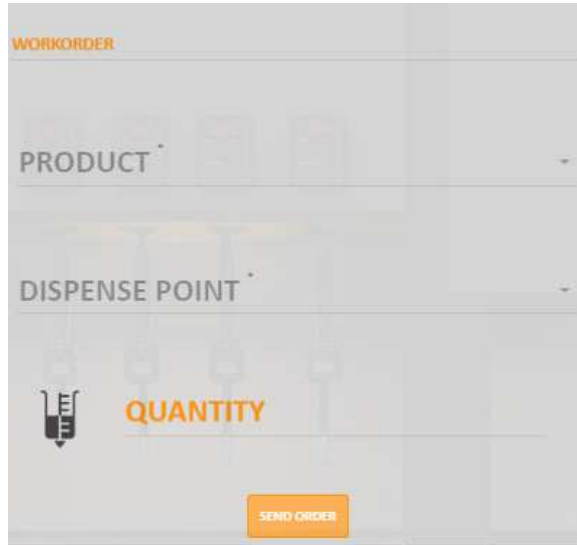

Depending on the order mode, you can insert:

Workorder / Product / Dispense Point / Quantity

NOTE: When you choose a product, only the points in which you can dispense that product are available.

In the left part you can see several icons that show the following items.

In the  icon you can see the transactions in progress

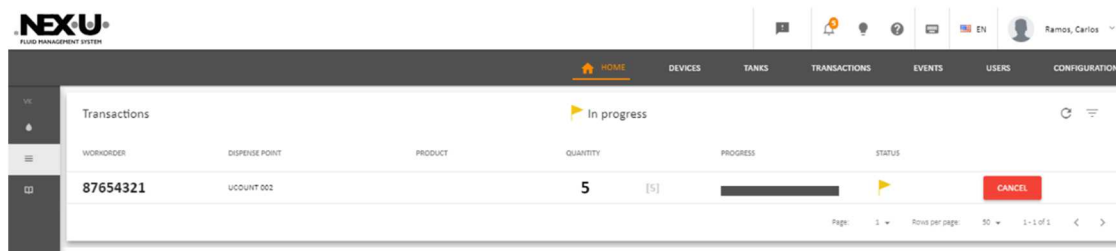

10 U-LINK MENUS

DEVICE TURN ON/OFF

If you press any of the UP/DOWN keys, the display is activated. Then the name of the equipment is briefly displayed. The gun automatically switches off after 30 seconds of inactivity to save energy

MAIN MENU

Press ENTER and CANCEL buttons until the setup menu is displayed (it takes about 3 secs).

The SETUP screen will appear.

Pressing the UP/DOWN buttons allows navigation through menu functions.

RF TEST

This menu allows us to obtain the RSSI transmission signal value (in dBm) and to display it graphically in order to get an idea of how good or bad is our signal. As well, the more “archs” you will see, the better signal value (at least two archs recommended)

CALIBRATE

See chapter 15

EDIT PARAMS / FACTOR K

Calibration factor (K-factor): allows the calibration factor to be changed manually without performing the vessel calibration process. Use the UP/DOWN buttons to change it and press the ENTER button to confirm.

Calibration Factor = Qty on Screen / Real Dispensed Qty * 1000

DISPLAY ORIENTATION

This menu allows you to change the direction of the display (normal or inverted), so that the gun can be adapted to the specific location and the way it is used. Use the UP/DOWN arrows to select the desired screen direction (standard or upside down – inverted) and press the ENTER button to confirm and exit the menu.

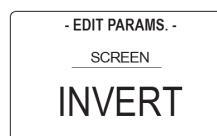
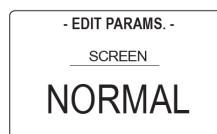
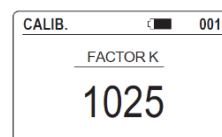
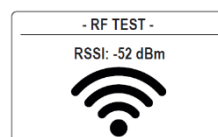
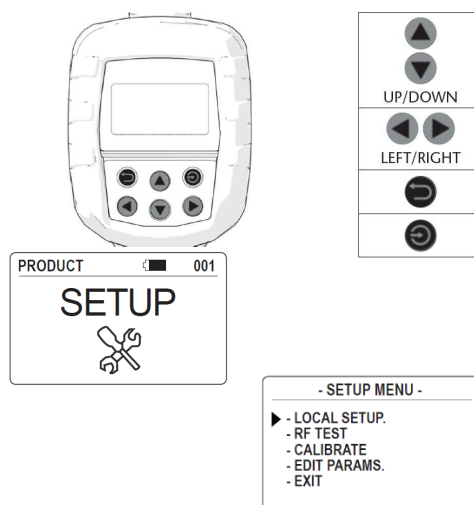

11 U·DAT OPERATION

DEVICE TURN ON/OFF

The U·Dat can be operated through the alphanumeric keyboard. In some occasions, the selection of some field will be required on touch screen.

To turn on the device, power up the unit. After a while, the home screen will show up.

Regardless of the menu shown on screen, after a period of inactivity, the application will come back to the home screen.

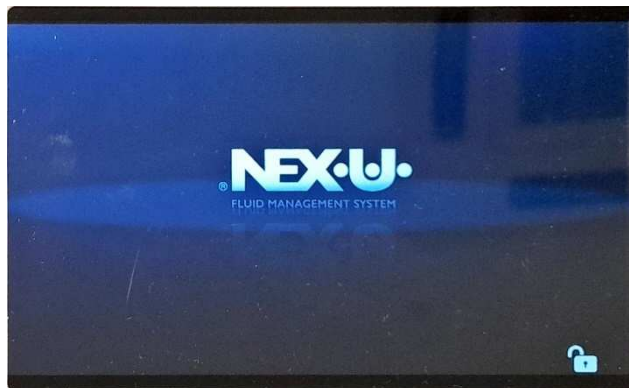





MAIN MENU

From the home screen, press the shortcut key associated with the unlock icon to access the main menu.

This screen shows the selected



language  UK, the U·Dat local parameter  001, the date and time  17 Oct 2023  13:42, and the available menus:

Dispense , Stocks , Transactions  and Configuration . Press the associated shortcut key to access the desired menu.



11.1 DISPENSE MENU

The “Dispense” menu allows, once the operator has inserted the identification, to dispense the quantity of the selected product.

While you are setting up the dispensing, you can return to the previous screen by pressing  and to the home screen by pressing the  key.

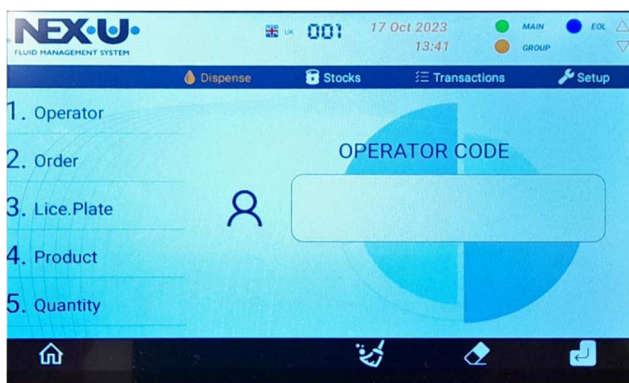

To start dispensing, follow the following procedure:

1. Operator

Select the “operator” field on the screen and enter your code by keyboard. Then, press







Optionally, you can log in by using RFID or magnetic key if these devices have been provided to you. NOTE: The RFID code is not set by the customer but by the card manufacturer.

2. Order

In the “order” menú, select the “work order” field and enter the order you want to execute.

Press  to confirm.

3. Product



Select the product field on the screen and use the shortcut keys associated with the navigation buttons   to select the fluid to dispense. Then, select the dispensing point field on the screen and, using  , select the desired hose reel.

Press  to confirm.

5. Quantity

Select the “Quantity” field on the screen and enter the volume to be dispensed using the keyboard. Press  to confirm.

6. Summary and Confirmation

Finally, a summary screen that presents all the data entered in the 4 previous steps is displayed on the screen. If any of these parameters need to be modified press the cancel key  and if they are correct press the confirmation key  to start the dispensing.

TRANSACTIONS IN PROGRESS

Immediately after launching a transaction from the “dispense” menú, the “transactions in progress” screen is displayed.

All transactions in progress are displayed on the screen. Using the navigation buttons and you can scroll through the list.

EMERGENCY STOP

Transactions in progress can be stopped by pressing the cancellation button. Then, the cancellation confirmation of the order will be displayed on the screen. Enter the operator code and press the confirmation button to confirm the transaction cancellation.

The emergency stop can only be used by the operator who has initiated the order or by the “manager” user.

11.2 STOCKS MENU

The “Stocks” menu shows the status of each tank and the associated dispensing units as well as an evolution of the stock.



11.3 COMPLETED TRANSACTIONS MENU

To see the completed transactions press the shortcut key associated with the button . Press  to alternate the transactions in progress view.

11.4 CONFIGURATION MENU

The “Configuration” menu lets the engineer that makes the configuration to set the local parameters. Please check Chapter 4.5.3.

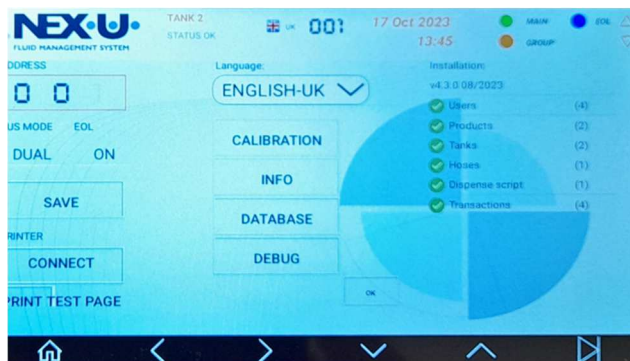

PRINTER: Just in case you want to link a NEX·U· Bluetooth® ticket printer, please click on CONNECT. A new screen will appear and the possible printers will appear. If no printers appear, please click on SCAN. Once you have found the desired printer, please click on the printer and it will be linked to the system.

Once the Bluetooth® ticket printer configuration has been made, you can print a test page (PRINT TEST PAGE)
CALIBRATION: Please check Chapter 12



INFO: If you click on that option, you will have these options

- Factory Reset: The U-Dat will go back to default values.
- Get Users: If you click on that option, all the installation will acquire the administrators and operators from the U-Track.
- Users: The U-Dat will show the administrators and operators in the memory.
- Get Info:
- Remove Transactions: All the recorded transactions will be removed.
- Remove Transactions in Progress: All the in-progress transactions will be removed.

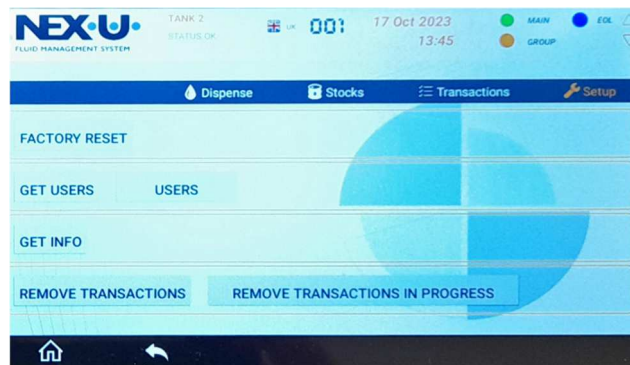

DATABASE: If you click on that option, you will have these options

- Select Product: When you order a dispense, the screen will show the products in the installation when the desired one is chosen, the available hose reels for those product are shown.
- Select Hose Reel: When you order a dispense, the hose reel is required and then the quantity.
- U-Net IP: The U-Net IP will appear on the screen.

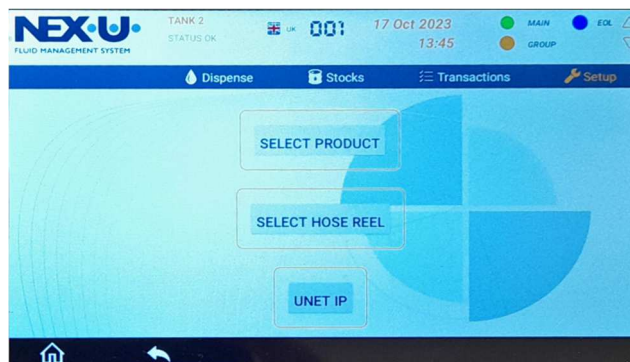

DEBUG: Only for manufacturer service purposes.

12 U-VISION+ OPERATION

If the unit has been properly configured a short press on the power button shows on the screen the “ready for use” mode.



When the screen is displayed, the backlight is activated during 10 seconds and then turned off. After 30 seconds since the display is activated and if there is no transaction in progress, the unit will turn off to save energy. If the unit is off press the power button to activate it.

If the screen is ON and you want to activate the backlight press briefly the power button in order to activate it for 10 seconds.

Once it is ON, you will have to insert the following data

- User Pin.
- Job Order.
- Quantity.

You will have to use the  and  keys to go to the desired digit.

For going to the next (previous) position, you have to press  or .

If you have chosen “Preset”, then only the pre-recorded job orders will appear when the job order is requested.

Once you have finished, please press .

In the “ready for use mode” are displayed the product associated to the hose reel, the battery charge indicator, the wireless strength and the hose reel number paired.

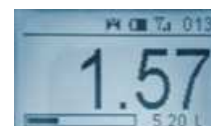

13 U·LINK MODES

There are three dispensing modes for the U·Link.

Standard mode: In this case, the user must enter technician PIN number manually io with an RFID tag, then job order and quantity

Preset: In this case, the job order is pre-recorded in the U·Track (go to Transactions / Presets menu) and the user must scroll and choose the job order in the U·Link. Then quantity confirmation in the U·Link is required.

WORKORDER	PRODUCT	QUANTITY	REPETITIONS	DATE	OPERATOR
<input type="checkbox"/> TEST	MOTOR OIL 80001	5	UNLIMITED	29/10/20 16:26	Samosa, Admin
<input type="checkbox"/> POTATO	SYNTHETIC OIL 80002	5	4	21/1/21 18:13	Ramos, Carlos
<input type="checkbox"/> TFST2	WINDSHIELD WASH	5	UNLIMITED	10/6/21 17:23	Samosa, Admin

Remote mode: In this case, job order is launched in the virtual keypad then quantity confirmation in the U·Link is required.

WORKORDER
125DR T02

PRODUCT
MOTOR OIL

DISPENSE POINT
ULINK 011

QUANTITY
5.0

SEND ORDER

14 HOSE REEL CALIBRATION

There are two ways of reaching to the calibration menu

1. Go to the configuration menu, two consecutive access codes are required. The first one is (four dots) and then the system will ask for another one which is NEXU. You will go to the following screen



2. Or, you can go to the configuration menu and only one code is required. The code is CAL

In both cases, you will see this screen

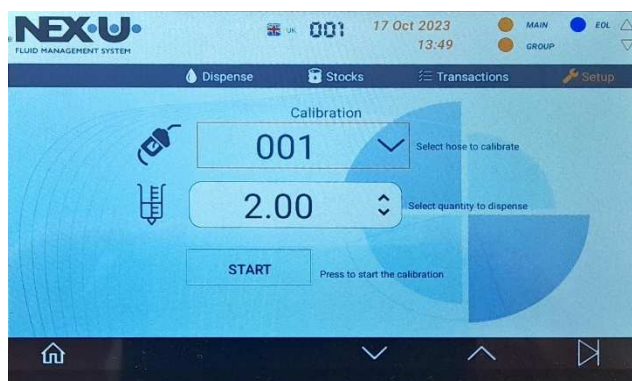

Insert the hose reel you want to calibrate.

Insert the volume of the calibrated measure in which the calibration.

Press “Start”.

Deliver the quantity that was set in the “Requested Quantity” field.

Then you will have to press CALIBRATE and the new K Factor will appear on screen and the delivery device will be calibrated.

15 U-LINK CALIBRATION

DEVICE TURN ON/OFF

If you press any of the UP/DOWN keys, the display is activated. Then the name of the equipment is briefly displayed. The gun automatically switches off after 30 seconds of inactivity to save energy



CALIBRATE

Enter the amount to be dispensed (typically the amount indicated on the container) by selecting the desired digit using the LEFT/RIGHT buttons and changing its value using the UP/DOWN buttons.

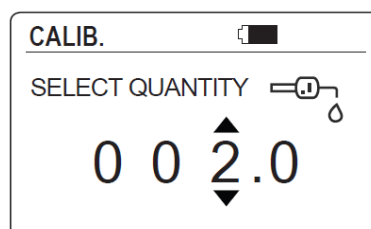
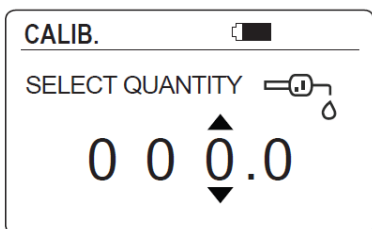

Once the amount is set, press ENTER to confirm and you will be prompted to confirm that you are not pressing the trigger.

Make sure that the trigger is not pulled and press the ENTER button below.

The pre-selected quantity is displayed and you can start dispensing fluid into the container. To ensure that you can adjust while dispensing, a quantity equal to twice the value entered is preset for safety.

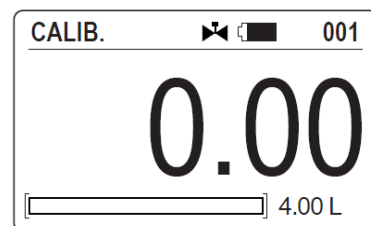
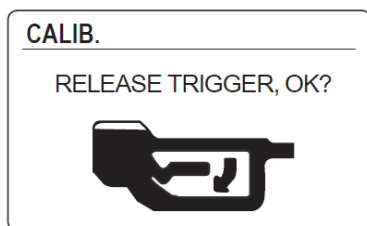

When you have dispensed the target amount into the calibrated container, release the trigger to stop the fluid supply.

Press the CANCEL button and you will be asked if you wish to cancel to finish dispensing. If we have finished, we will confirm by pressing the ENTER button. If, on the contrary, we want to continue dispensing, we will press the CANCEL button.

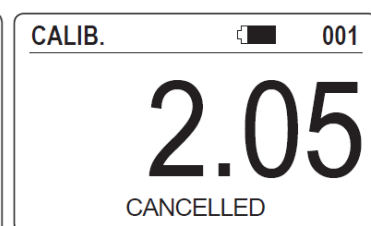
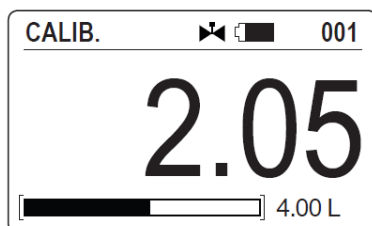

The dispensed quantity is displayed and after 5 seconds the message “QTE REAL?” is shown on the display. We must indicate the actual dispensed quantity, which will be the quantity registered by the calibrated container.

The UP/DOWN buttons are used to modify the digit value and the LEFT/RIGHT arrows are used to change the digit.

Once this amount has been set, press the ENTER button to confirm and the gun automatically displays the calculated calibration factor:

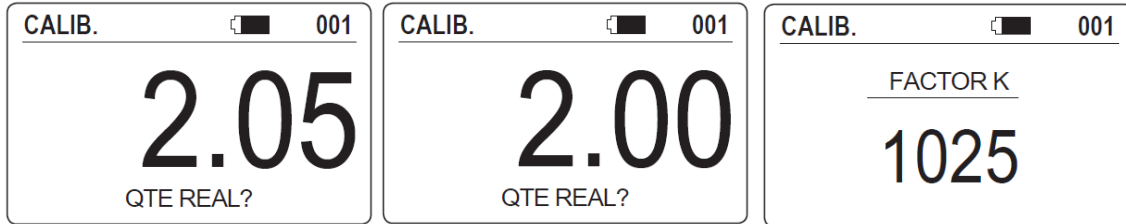

EDIT PARAMS / FACTOR K

You can calibrate the unit by changing the K factor manually without performing the vessel calibration process.

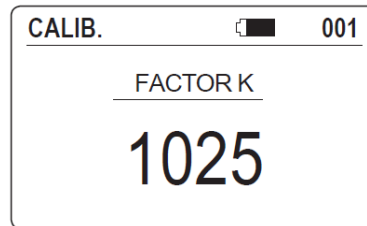

Use the UP/DOWN buttons to change it and press the ENTER button to confirm.

Calibration Factor = Qty on Screen / Real Dispensed Qty * 1000



16 U-TANK ANALOGUE PROBES CALIBRATION

This section only applies to analogue probes.

Insert the by-pass key into the unit and switch from normal position () to by-pass position (). The main menu will appear on screen:

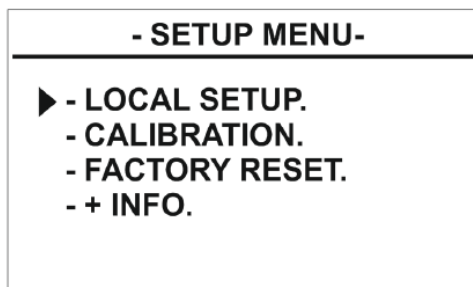

WARNING: When the unit is in bypass mode, both the general air supply and the pump control valves will be permanently activated.

When making initial configuration (or after replacing a probe), each analogue probe must be calibrated. Note that before probe calibration, the configuration for the tank must have been already received, otherwise an error message will pop up.

The arrow at the left side of the screen indicates the currently selected option.

Use the UP/DOWN keys on the keypad to go to CALIBRATION and press "OK" to confirm.

- Select the channel that is going to be calibrated (1 or 2). Use the UP/DOWN keys on the keypad to select the desired option and press "OK" to confirm, or press  to go back to the main menu.
- The unit will ask to put the probe outside of the fluid. Make sure that the probe to be calibrated is at atmospheric pressure (outside of the tank, not submerged or in contact with the fluid) and press "OK" to confirm.

NOTE: If the probe is at atmospheric pressure and an acceptable value is measured, the system will proceed to the next screen, otherwise an error message will appear.

- Then set the probe height inside the tank. This height is the distance between the bottom end of the probe and the bottom of the tank. Use UP/DOWN keys on the keypad to enter the value (in centimeters) and press "OK" to confirm, or press  to go back to the previous step.
- At this point, the display will show "OK! CALIBRATION FINISHED", to confirm that the calibration values have been successfully recorded.

NOTE: To protect the probe from dirt or debris on the bottom of the tank, it is not recommended to let the probe touch tank bottom.



2024_07_24-10:02

PARTS & TECHNICAL SERVICE GUIDE

NEX·U·
®
FLUID MANAGEMENT SYSTEM